



7

VM

7.1	153
7.2	153
7.3	154
7.4	154
7.5	155
7.6	156
7.7	157
7.8	160
7.9	162





7.1

STM –

STM  
B5,

SG-AISI UNI 1706  
(63, 71, 80)

G20 ISO 185  
(90,100 112).  
100Cr6,

16CrNi4 UNI 7846



1:1.4 1: 7.5.

: ± 0.5%

: ±1%

84%,

7.2

VM	F F1, F2, F3, F4 C P P/F1, P/F2, P/F3, P/F4 P/C	63 71 80 90 100 112	VM F1 63			
	T TA ... H	56 ... 315	A ... ML	VM F1 63 T 63 B 4 B5		

7.3

- :

B5.

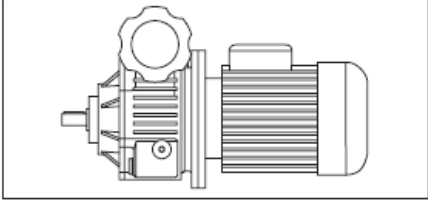

F

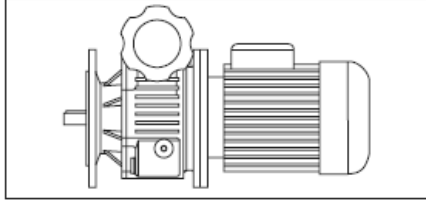

F1, F2, F3, F4

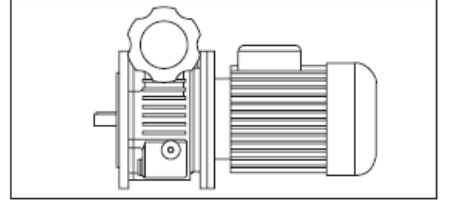

C

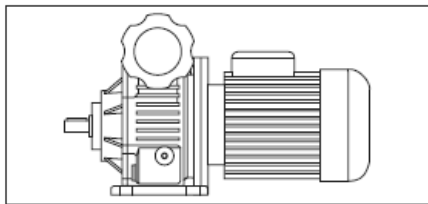

P

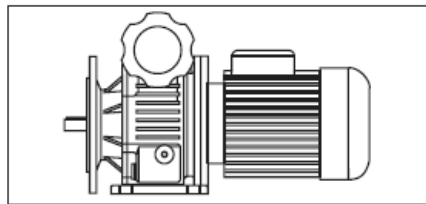

P/F1, P/F2, P/F3, P/F4

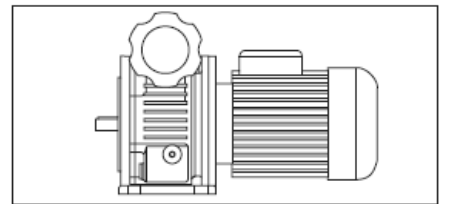

P/C

VMC VMP/C

7.4

1.9

1)

;



2)

100

1000

A)

M1.

B)

C)

VM	( )			AGIP TRANSMISSION FLUID V.E.
	M1	M3	M4	
63	0.110	0.200	0.200	
71	0.180	0.400	0.300	
80	0.300	0.800	0.600	
90	0.650	1.400	0.900	
100	1.2	2.2	2.2	
112				

7.5

F, F1, F2, F3, F4

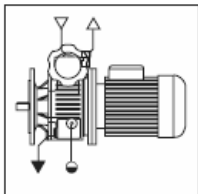

M1

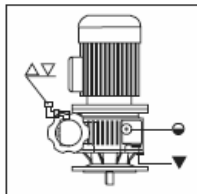

M3

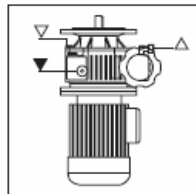

M4

C

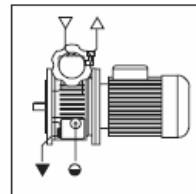

M1

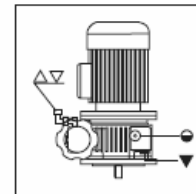

M3

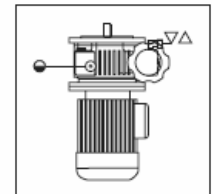

M4

- △ Сапун
- ▽ Заливная пробка
- Уровень
- ▼ Сливная пробка

P, P/F1, P/F2, P/F3, P/F4, P/C

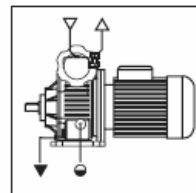

M1

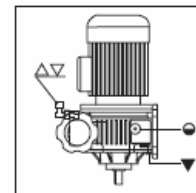

M3

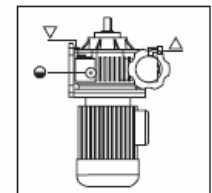

M4



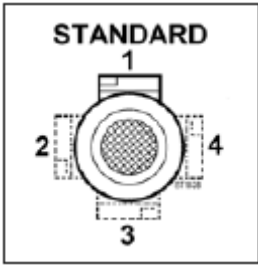
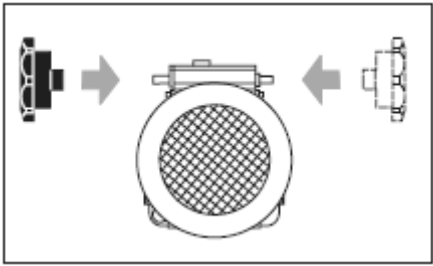

7.6

$$F_a = 0.2 \times F_r$$

	Fr[N]	
	$n_2 = 190 \text{ min}^{-1}$	$n_2 = 1000 \text{ min}^{-1}$
<b>63</b>	750	450
<b>71</b>	1100	800
<b>80</b>	1650	950
<b>90</b>	2000	1150
<b>100</b>	4000	2200
<b>112</b>		

VMC VMP/C



7.7

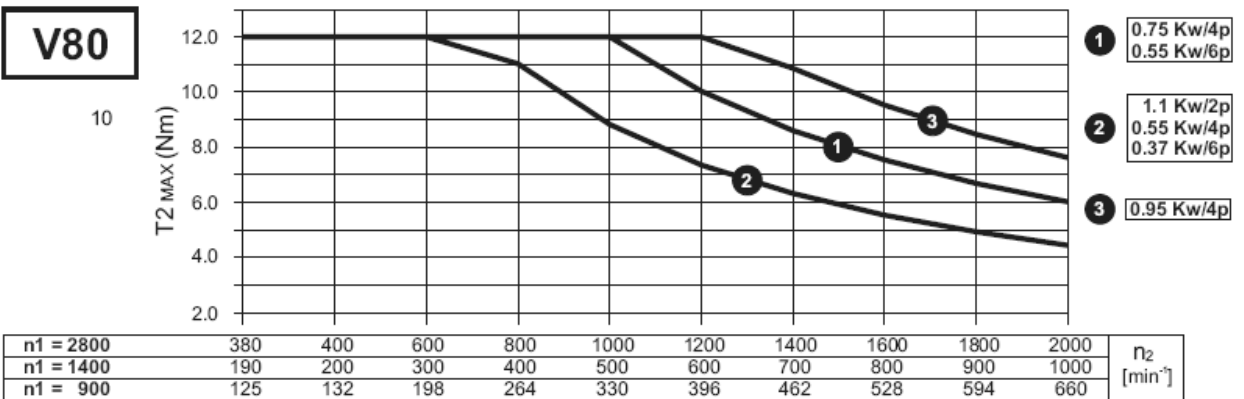
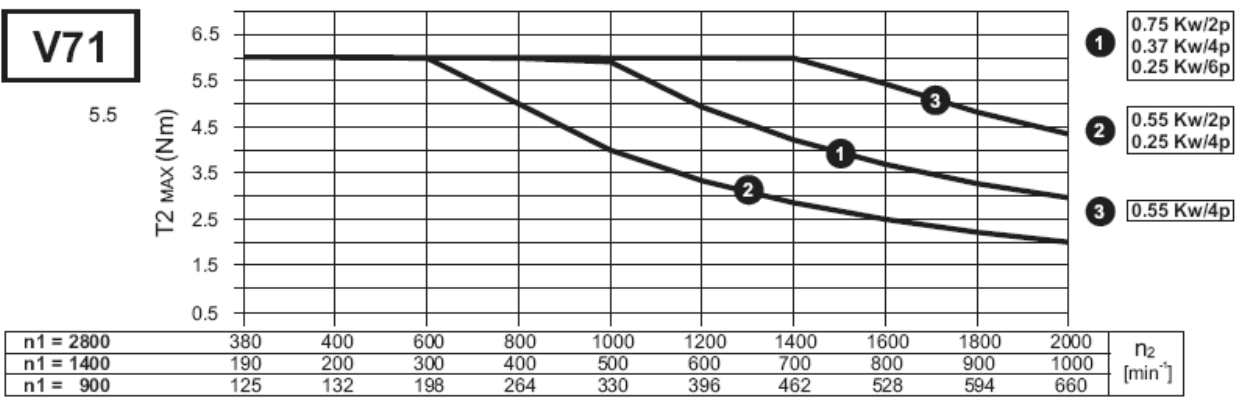
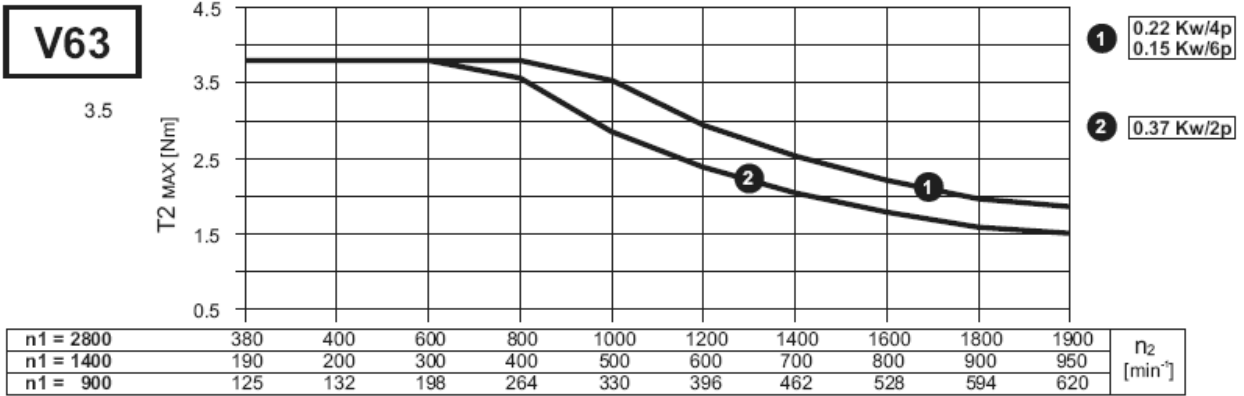



### V90

24



- 1 1.5 Kw/4p  
1.1 Kw/6p
- 2 2.2 Kw/2p  
1.1 Kw/4p  
0.75 Kw/6p
- 3 1.8 Kw/4p

n1 = 2800	380	400	600	800	1000	1200	1400	1600	1800	2000	n2
n1 = 1400	190	200	300	400	500	600	700	800	900	1000	[min <sup>-1</sup> ]
n1 = 900	125	132	198	264	330	396	462	528	594	660	

### V100

46

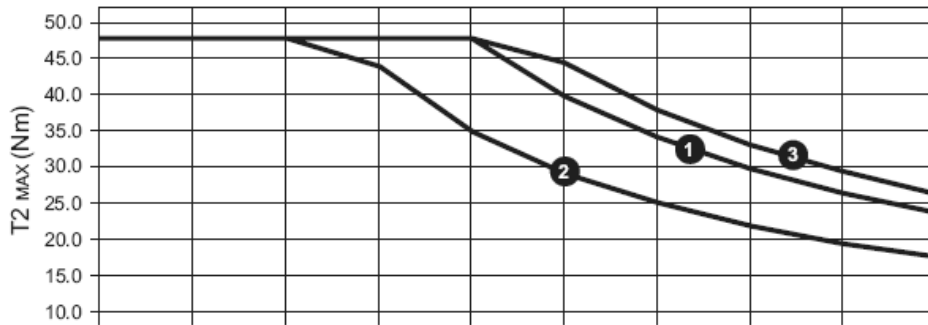

- 1 3 Kw/4p
- 2 2.2 Kw/4p  
1.5 Kw/6p
- 3 2.2 Kw/6p

n1 = 1400	190	200	300	400	500	600	700	800	900	1000	n2
n1 = 900	125	132	198	264	330	396	462	528	594	660	[min <sup>-1</sup> ]

### V112

46

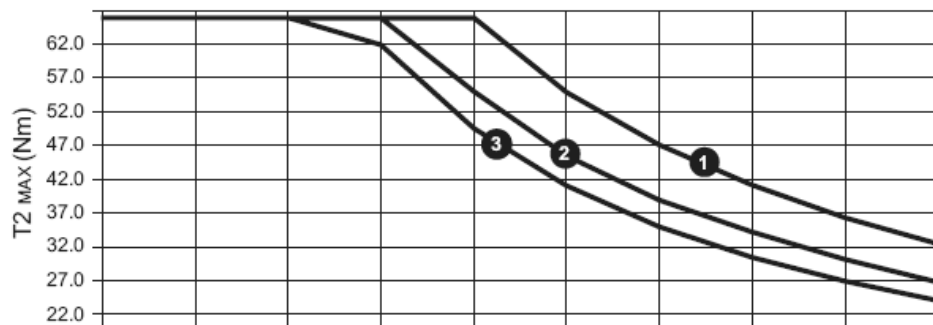

- 1 4 Kw/4p
- 2 2.2 Kw/6p
- 3 3.0 Kw/4p

n1 = 1400	190	200	300	400	500	600	700	800	900	1000	n2
n1 = 900	125	132	198	264	330	396	462	528	594	660	[min <sup>-1</sup> ]



P <sub>1</sub> [kW]	n <sub>1</sub> min <sup>-1</sup>	n <sub>2</sub>		T <sub>2</sub> [Nm]		VM
		max	min	max	min	
0.15	880	620	125	1.9	3.8	VM 63
0.18	1380	950	190	1.5	3.8	VM 63
	880	660	125	2.2	6.0	VM 71
0.22	1350	950	190	1.9	3.8	VM 63
0.25	1400	1000	190	2.0	6.0	VM 71
	900	660	125	3.0	6.0	VM 71
0.37	2770	1900	380	1.5	3.8	VM 63
	2800	2000	380	1.5	6.0	VM 71
	1400	1000	190	3.0	6.0	VM 71
	910	660	125	4.5	12.0	VM 80
0.55	2820	2000	380	2.2	6.0	VM 71
	1400	1000	190	4.4	6.0	VM 71
	1410	1000	190	4.4	12.0	VM 80
0.75	910	660	125	6.7	12.0	VM 80
	2820	2000	380	3.0	6.0	VM 71
	1410	1000	190	6.0	12.0	VM 80
0.95	920	660	125	9.0	24.0	VM 90
	1410	1000	190	7.6	12.0	VM 80
	2830	2000	380	4.4	12.0	VM 80
1.1	1410	1000	190	9.0	24.0	VM 90
	920	660	125	13.4	24.0	VM 90
	1420	1000	190	12.0	24.0	VM 90
1.5	940	660	125	17.6	48.0	VM 100
	1420	1000	190	14.4	24.0	VM 90
2.2	2850	2000	380	9.0	24.0	VM 90
	1430	1000	190	17.6	48.0	VM 100
	940	660	125	26.7	48	VM 100
	940	660	125	26.7	64	VM 112
3	1430	1000	190	24.1	48	VM 100
	1430	1000	190	24.1	64	VM 112
4	1430	1000	190	32.1	64	VM 112

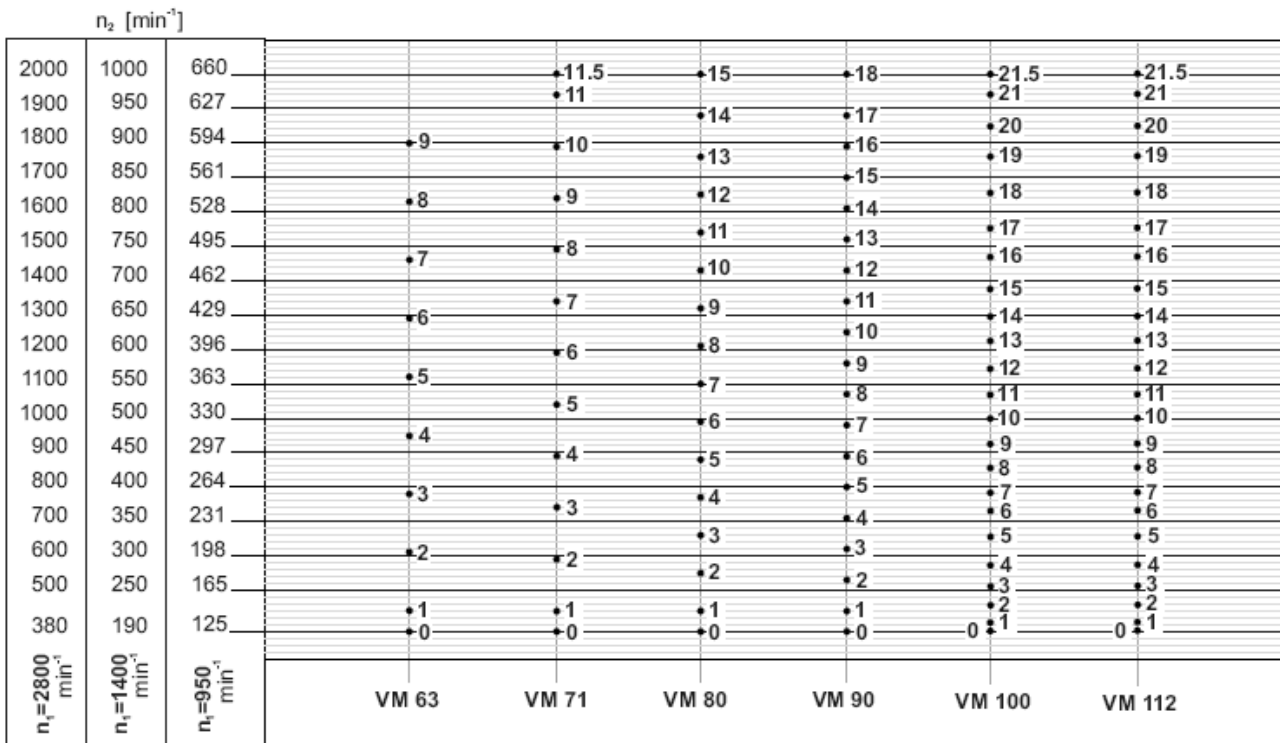





7.8

F1, F2, F3, F4

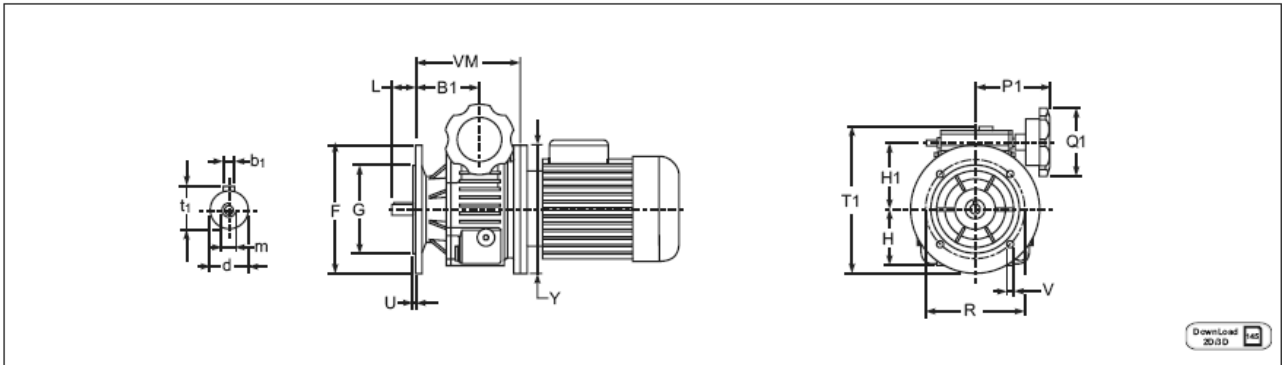

Download 2000

		F	G (g6)	R	T1	U	V	B1	H	H1	L	P1	Q1	VM	Y	d	b1	m	t1
VM 63	F1	140	95	115	165	3.5	9	65.5	57	75	22 (30)	100	90	112	140	11 (14)	4 (5)	M4 (M5)	12.5 (16)
	F2	160	110	130	175	3.5	10												
	F3	120	80	100	155	3	9												
	F4	200	130	165	195	3.5	13												
VM 71	F1	160	110	130	189	3.5	10	80.5	70	87.5	30 (40)	100	90	131.5	160	14 (19)	5 (6)	M5 (M6)	16 (21.5)
	F2	200	130	165	209	3.5	13												
	F3	120	80	100	169	3	9												
	F4	140	95	115	179	3.5	9												
VM 80	F1	200	130	165	232	3.5	13	95	89	107	40 (50)	110	90	152.5	200	19 (24)	6 (8)	M6 (M8)	21.5 (27)
	F2	160	110	130	212	3.5	10												
	F3	250	180	215	257	4	15												
VM 90	F1	200	130	165	252	3.5	13	105.5	105	126	50 (60)	118	90	172.5	200	24 (28)	8 (8)	M8 (M10)	27 (31)
	F2	250	180	215	277	3.5	15												
	F3	160	110	130	232	3	10												
VM 100 VM 112	F1	250	180	215	320	4	15	122.5	129.5	158	60 (80)	152.5	119	207.5	250	28 (38)	8 (10)	M10 (M10)	31 (41)
	F2	300	230	265	325	4	15												

: F1 –



C

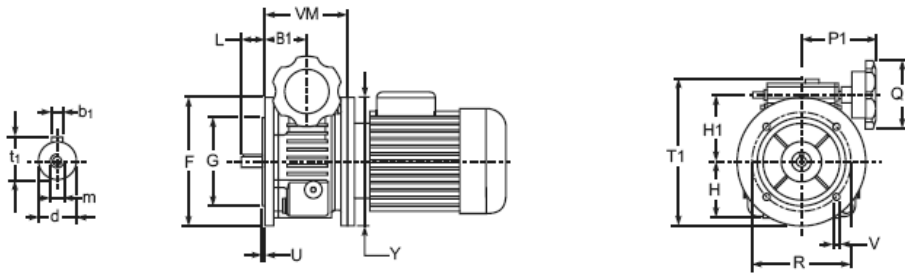

	B1	F	G	H	H1	L	P1	Q1	R	T1	U	V	VM	Y	d	b1	m	t1
<b>VM 63</b>	41.5	140	95	57	75	22 (30)	100	90	115	165	3	M6	88	140	11 (14)	4 (5)	—	12.5 (16)
<b>VM 71</b>	52.5	160	110	70	87.5	30 (40)	100	90	130	189	3.5	M8	103.5	160	14 (19)	5 (6)	—	16 (21.5)
<b>VM 80</b>	61	200	130	89	107	40 (50)	110	90	165	232	3.5	M10	118.5	200	19 (24)	6 (8)	—	21.5 (27)
<b>VM 90</b>	68.5	200	130	105	126	50 (60)	118	90	165	252	3.5	M10	135.5	200	24 (28)	8 (8)	—	27 (31)

P

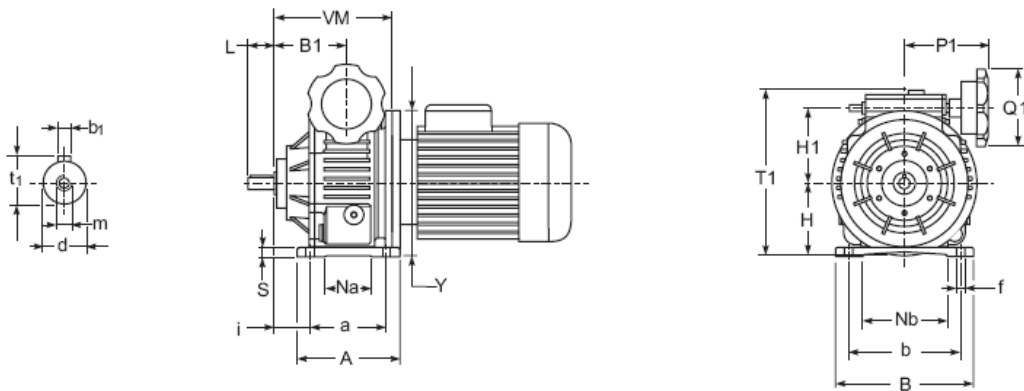

	A	a	B	B1	b	f	H	H1	i	L	Nb	Na	P1	Q1	S	T1	VM	Y	d	b1	m	t1
<b>VM 63</b>	110	86	140	65.5	110 <sup>0</sup> <sub>+8</sub>	10	71	75	22	22 (30)	90	70	100	90	8	162	112	140	11 (14)	4 (5)	M4 (M5)	12.5 (16)
<b>VM 71</b>	115	90	155	80.5	120 <sup>0</sup> <sub>+14</sub>	10	81	87.5	36.5	30 (40)	100	50	100	90	10	190	131.5	160	14 (19)	5 (6)	M5 (M6)	16 (21.5)
<b>VM 80</b>	135	110	200	95	150 <sup>0</sup> <sub>+20</sub>	11	102	107	42.5	40 (50)	120	60	110	90	12	234	152.5	200	19 (24)	6 (8)	M6 (M8)	21.5 (27)
<b>VM 90</b>	140	115	235	105.5	200 <sup>0</sup> <sub>+10</sub>	11	125	126	55.5	50 (60)	130	60	118	90	16	277	172.5	200	24 (28)	8 (8)	M8 (M10)	27 (31)
<b>VM 100 VM 112</b>	250	220	290	122.5	255	14	150	158	25.5	60 (80)	150	120	152.5	119	20	336.5	207.5	250	28 (38)	8 (10)	M10 (M10)	27 (41)



7.9

0 - 2000

1

2

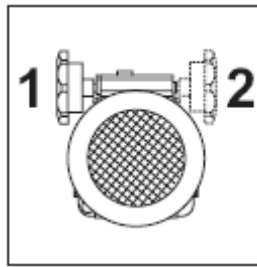

0,

	A	B	C	D	E	F	G
<b>03-05</b>	90	57	22	8	6	3	47
<b>10-20</b>	90	57	22	10	6	4	47

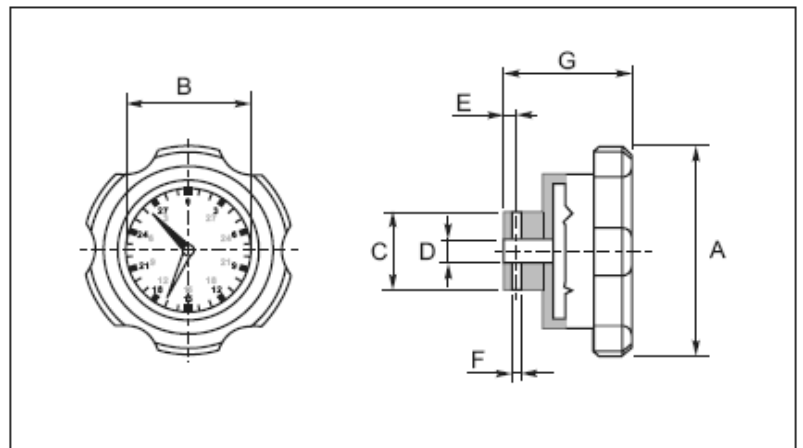



NAMUR

30 9

