	<h1>MAINTENANCE BOOKLET</h1> <p>(Gearboxes, Speed Variators, Bevel Gearboxes )</p> <p>Notice :</p> <p>Please check the revision in your possession as well as the table reporting all the updates in the new revision.</p>
---	--

	<b>Update table</b>	
Page	Paragrafo Charter	Description
-	-	Addition of the specifications for gearboxes certified for potentially explosive working environments as per "ATEX " set of norms 94/9/CE.
10	4.3	Instructions for installing COUPLING



## INDICE

<b>1. GENERAL INFORMATION</b>	<b>4</b>
INTRODUCTION	4
1.2. PRODUCT IDENTIFICATION	4
1.3. WARRANTY – TECHNICAL/AFTER SALES CONDITIONS	6
1.4. OVERALL SAFETY INFORMATION	6
1.5 RECYCLING – ENVIRONMENTAL CLASH	6
<b>2. SUPPLY CONDITIONS</b>	<b>7</b>
2.1. PRELIMINARY WARNINGS	7
2.2. PACKING	7
2.3. LIFTING AND HANDLING	7
<b>3. STORAGE</b>	<b>7</b>
<b>4. INSTALLATION</b>	<b>8</b>
4.1. PRELIMINARY WARNINGS – ENVIRONMENTAL CONDITIONS	8
4.2. INSTALLATION	8
4.3 INSTRUCTIONS FOR INSTALLING COUPLING	10
4.4. OIL FILLING	11
<b>5. SET UP - OPERATION</b>	<b>12</b>
5.1. GENERAL INSPECTION BEFORE SETTINGUP THE PRODUCTS	12
5.2. DESCRIPTION OF THE OPERATING MODALITIES	13
<b>6. MAINTENANCE</b>	<b>13</b>
6.1 PRELIMINARY INFORMATION	13
6.2 PRECAUTIONARY ACTIVITY	13
6.3. SPARE PARTS – AFTER SALES SERVICE	14
6.4. ROTTAMAZIONE / STORAGE – RECYCLING	14
<b>8. VALIDITA' DEL DOCUMENTO E INDICE DI REVISIONE</b>	<b>16</b>
<b>8. VALIDITY AND REVISION INDEX</b>	<b>16</b>

### LEGENDA - SIMBOLOGIA – KEYS - SYMBOLS

KEY	DESCRIPTION	KEY	DESCRIPTION
	DANGER		N.B.
	FIRE DANGER		READ THE BOOKLET
	ACCIDENT COVERAGE		HOT SURFACE

	PRESCRIPTIONS LISTED BELOW REFER TO PRODUCTS COVERED BY ATEX DIRECTIVE 94/9/CE
--	--

## 1. GENERAL INFORMATION

### INTRODUCTION

Aim of this booklet is to provide all information needed for personal safety, appropriate storage, use and maintenance of the STM products. Our products have been manufactured pursuing a long lifetime reliability. Such a goal is achieved by employing updated project design procedures as well as high quality materials, technologically advanced production systems and CNC centres surveilled and monitored 24 hours a day to reach high quality standards and high productivity. Special care is paid to the components assembly. Along each activity, from the designing to the distribution, is currently carried out in accordance with our own Quality control procedure in conformity with standard ISO 9001 rules.



In order to safeguard such a high performance level it is requested to carefully read the information herewith reported and keep a copy nearby the product.

The general instructions hereby given apply to ( motorised ) gearboxes, ( motorised ) mechanical speed variators, ( motorised ) bevel gearboxes for both standard and special versions.



STM SpA gearboxes, mechanical speed variators and torque limiters are mechanical devices for industrial use and incorporation in more or less complex machines. Consequently, they should not be considered neither self standing machines for a pre-determined application such as "MSD" '98/37/CE nor safety devices.

### 1.2. PRODUCT IDENTIFICATION

Every ( motorised ) gearbox and mechanical speed variator is equipped with a nameplate where all necessary technical datas are specified. The main types of nameplate for all different configurations are available in the following chart :

Tipo/Type		M
Rapp./Ratio	Date	
Cod./Code	OL/WO	
<b>S.T.M.</b>		<b>BOLOGNA</b> Made in Italy



**Tipo/Type:** gearbox description  
**M:** mounting position  
**Rapp./Ratio:** reduction ratio  
**Data/Date:** production date  
**Cod./Code:** product code  
**OL/WO:** Work order number



TARGHETTA PICCOLA TP - SMALL NAMEPLATE



	<h2 style="margin:0;">S.T.M.</h2> BOLOGNA Made in Italy	
Tipo Type		M
OL WO	Date	
Cod. Code	Rapp. Ratio	

**Tipo/Type:** gearbox description  
**M:** mounting position  
**Rapp./Ratio:** reduction ratio  
**Data/Date:** production date  
**Cod./Code:** product code  
**OL/WO:** Work order number

BIG NAMEPLATE

	<table border="1" style="width:100%; border-collapse: collapse;"> <tr><td style="width:100%;">OL/WO</td></tr> <tr><td style="width:100%;">ATEX</td></tr> <tr><td style="width:100%;">PI</td></tr> <tr><td style="width:100%;">N1</td></tr> <tr><td style="width:100%;">FT_ATEX_REV_</td></tr> <tr><td style="width:100%;">S.T.M.</td></tr> <tr><td style="width:100%;">BOLOGNA</td></tr> <tr><td style="width:100%;">Made in Italy</td></tr> </table>	OL/WO	ATEX	PI	N1	FT_ATEX_REV_	S.T.M.	BOLOGNA	Made in Italy	<p><b>OL/WO:</b> Work order number  <b>ATEX:</b> Family, type, temperature class or max surface temperature  <b>PI:</b> max input power allowance  <b>N1:</b> max input speed allowance  <b>FT_ATEX_REV_:</b> Reference to "ATEX" internal paperwork</p>
	OL/WO									
	ATEX									
	PI									
N1										
FT_ATEX_REV_										
S.T.M.										
BOLOGNA										
Made in Italy										
<p> <b>CE marking</b></p> <ul style="list-style-type: none"> <li>Environmental limits : environmental temperature between -20°C and + 40°C</li> <li>Max surface temperature allowed : T4 for 2G and 135°C for 2D. It is possible, upon request and verification of the declassified allowed power, to certify the temperature class T5 for 2G and 100°C for 2D.</li> </ul>										
<p>ADDITIONAL "ATEX" NAMEPLATE</p>										

  	<b>SPECIFICATIONS RELEVANT TO "ATEX" PRODUCTS</b>																		
	<p><b>- Application field</b></p> <p>ATEX set of norms ( 94/9/CE) is referred to electric and non-electric products which are used and run in a potentially explosive environment. The potentially explosive environments are divided into different groups and zones according to the probability of their formation.</p> <p>STM products are in conformity with following classification :</p> <ul style="list-style-type: none"> <li>Gruppo: II – Group : II</li> <li>Categoria: Gas 2G polveri 2D – Type : Gas 2G dust 2D</li> <li>Zona: Gas 1 – Polveri 21 – Zone : Gas 1 – Dust 21</li> </ul> <p><b>Max surface temperature allowed</b></p>																		
	<table border="1" style="margin: auto; border-collapse: collapse;"> <thead> <tr><th colspan="2"><i>Max surface temperature</i></th></tr> <tr><th>Temperature class</th><th>Max surface temperature (C°)</th></tr> </thead> <tbody> <tr><td>T1</td><td>450</td></tr> <tr><td>T2</td><td>300</td></tr> <tr><td>T3</td><td>200</td></tr> <tr><td>T4</td><td>135</td></tr> <tr><td>T5</td><td>100</td></tr> </tbody> </table> <table border="1" style="margin: auto; border-collapse: collapse;"> <tr><td style="width: 20%;"></td><td>- ATEX temperature class of STM products</td></tr> <tr><td style="width: 20%;"></td><td>- ATEX temperature class on request</td></tr> </table>	<i>Max surface temperature</i>		Temperature class	Max surface temperature (C°)	T1	450	T2	300	T3	200	T4	135	T5	100		- ATEX temperature class of STM products		- ATEX temperature class on request
	<i>Max surface temperature</i>																		
Temperature class	Max surface temperature (C°)																		
T1	450																		
T2	300																		
T3	200																		
T4	135																		
T5	100																		
	- ATEX temperature class of STM products																		
	- ATEX temperature class on request																		
<p>STM products are branded temperature class <b>T4</b> per IIG ( gas environment ) and 135°C for IID ( dust environment ).  <b>In case of T5 temperature class it will be necessary to verify the declassified thermal limit power ( with reference to internal set of norms NORM_0198, available on our website : <a href="http://www.stmspa.com">www.stmspa.com</a>).</b></p> <p>The products of the family IID ( dust environment ) are defined by the max effective surface temperature.  Max surface temperature is determined in standard installation and environmental conditions ( -20°C and +40°C ) and in absence of dust remains on product surface.  Any other condition will modify the heat dissipation and consequently the temperature.</p> <p><b>- Products available in "ATEX" execution</b></p> <p>Products available in "ATEX" execution :</p> <ul style="list-style-type: none"> <li>Wormgearboxes ( RI, RMI, UI, UMI)</li> <li>Helical wormgearboxes ( CR, CB )</li> <li>Helical in line gearboxes ( AR, AM 1/2/3 )</li> <li>Bevel helical gearboxes ( OR, OM )</li> <li>Parallel shaft/Shaft mounted gearboxes ( PR, PM )</li> </ul>																			



  	<p><b>Specifiche di sicurezza adottate per prodotti "ATEX" – Safety specifications used for "ATEX" products.</b></p> <ul style="list-style-type: none"> <li>▪ only synthetic lubricants must be used</li> <li>▪ breather plugs ( if supplied ) must have a one direction valve</li> <li>▪ absence of plastic based surfaces or material potentially attracting electrostatic charge</li> <li>▪ application of irreversible thermosensitive thermometers</li> <li>▪ for installations in dusty environments (zone 2D, Z21, Z22) the client must necessarily arrange for a regular surface cleaning plan service intended to prevent significant material/dust deposit ( max thickness allowed 5mm ) on the gearbox housing.</li> </ul> <p>- <b>Limitations and use conditions</b></p> <p>Any modification on the gearbox mounting position or execution as well as any intervention ( i.e. disassembly, repair, etc. ) not previously by STM S.p.A. authorized will cancel the product conformity conditions to ATEX set of norms 94/9/CE.</p>
--	---

### 1.3. WARRANTY – TECHNICAL/AFTER SALES CONDITIONS

	<p>The product is guaranteed against construction faults for two years as from the date indicated on the nameplate. The warranty terms and conditions to be referred to are those contained in the product general price list. Any price inquiry for product repair will be examined only for medium/big sized gearboxes/speed variators and will have to be agreed with the after sales service of STM SpA. Regarding the procedure to return goods in non conformity with the requirements it is necessary :</p> <ul style="list-style-type: none"> <li>- to fill in the form " <b>After sales /Technical assistance and customer's service request for intervention form</b> " and fax it to the above mentioned number.</li> <li>- to wait for the confirmation reply from STM SpA.</li> <li>- To send the product free of transportation charges ( charged to the sender ) to STM SpA alongwith the form approved by STM SpA.</li> </ul> <p>STM SpA can not be held liable for any consequence, in terms of safety and system operation, which might result from improper use of the product other than that specified in this document. Any controversy will be heard before Bologna Court.</p>
---	---

### 1.4. OVERALL SAFETY INFORMATION

	<p>This booklet gives information to prevent dangerous conditions towards animals, people or object, which might occur while using the product.. It is therefore imperative to attain to the given instructions when installing, using or doing the maintenance. Customer is responsible for ensuring that installation staff and/or operators are made aware of these instructions. These indications regard the products only and not its applications, the safety of which must be specifically considered by those who use them, either directly or indirectly.</p> <p>The gearboxes, mechanical speed variators and bevel gearboxes must not be set running before the overall destination environment where they are inserted is fully declared in conformity with the legally valid regulations in the country where the product will be used ( for example set of norms MSD 98/37/CE ). For this reason, when writing down the booklet about his own construction, the manufacturer of the whole machine must keep in consideration all information and prescriptions object of this document.</p> <p><b>STM gearboxes, variators, bevel gearboxes and torque limiters are mechanical devices intended for industrial use and incorporation inside more or less complex machines. Consequently, they must neither be considered as independent machines for a pre-determined application following " MSD " 98/37/CE nor safety devices.</b></p>
---	---

  	<p>STM SpA herewith state its own conformity with ATEX norms 94/9/CE only for the gearbox. As far as its usage and incorporation in a more complex machinery is concerned, this will have to be eventually provided by the installer :</p> <ul style="list-style-type: none"> <li>• Always verify that components connected to the gearbox are appropriate following the norms.</li> <li>• Develop the analysis of the potential risks relating to connection with a motor</li> <li>• Carry out all prescriptions object of this booklet ( if not, the conditions of validity of the product conformity certification supplied by STM SpA will be void ).</li> </ul> <p>Before starting up any activity on gearboxes operating in potentially explosive environments you need to :</p> <ol style="list-style-type: none"> <li>a. Disconnect the gearbox from any power source by setting it in " out of service " condition.</li> <li>b. Make sure that an unintentional start up or motion of the application will not take place in any case.</li> <li>c. Carry out all the environmental safety precautions to grant the safety of the operator ( degassing, dust cleaning, make sure of the absence of external sources of tripping )</li> </ol>
--	--

### 1.5 RECYCLING – ENVIRONMENTAL CLASH

Special attention must be paid to collection and recycling of all products and components related to the gearbox, speed variator and/or bevel gearbox. More in detail, such precautions deal with :

- package recycling
- lubricant and plastic wrapping recycling
- product recycling

Recycling above mentioned products must be done according to the law valid in the country.

The standardised type of waste can be put into appropriate waste containers whereas special waste must be recycled according to the law prescriptions.

## 2. SUPPLY CONDITIONS

### 2.1. PRELIMINARY WARNINGS

The procedures of the STM company management system have been approved and found in conformity with UNI EN ISO 9001. Therefore, they are tested and suitable to be installed in the agreed mounting versions confirmed on customer's order.

	<p>The person receiving the goods is responsible to check that the data on the nameplate correspond to the goods ordered, that the product is complete and has not suffered damage during transportation. Any unconformity must be reported immediately to STM SpA or to the authorised dealer.</p> <p>The shafts are delivered with plastic safety protections and appropriate sticky tape wrappings of the keys to the shafts. Shafts and machined parts are protected by anti-oxide protective products. These must not be removed before installation.</p> <p>Gearboxes and/or speed variators, unless differently specified, are normally supplied with lubricant in the types and sizes specified on STM catalogues.</p>
---	--

	<p>STM products must be handled with safety tools so to maintain the product quality features. Handling, transport, unpacking and re-packing must be done by highly qualified personnel, aware of all safety norms implied in such actions.</p>
---	---

### 2.2. PACKING

The products are delivered packed in cardboard boxes, in some cases wrapped or protected with appropriate material to fill empty areas inside boxes. **Packages over Kg. 30 are set on wooden pallets and are easily accessible by transpallets.**

	<p>Do not move or store two or more packages on top of one another. Should it be necessary to pack the equipment again, do not forget to use the original packaging and take special care to protect the surfaces and the coupling shafts. Only transport the device if it is suitably packed and protected against knocks, dust and dirt.</p>
---	--

### 2.3. LIFTING AND HANDLING

**The handling of the product, packed or unpacked, might be dangerous for the operator because of both the equipment weight and its mechanical specifications.**

	<p>In full respect of the existing appropriate legislation, the user must use appropriate tools for correctly handling the products in accordance to his own safety system. His task is also to evaluate back-lumbar risks for the operators which eventually might imply the use of lifting mechanical devices and/or other tools for even well higher weights than Kg. 30 previously mentioned.</p> <p>Lifting and handling devices must be selected depending on the product specifications but always in full conformity with applicable safety legislation. For the handling of the packed product it is necessary to arrange suitable lifting devices for packages over Kg30, making sure to adequately protect against knocks on product surfaces and connecting parts. For the handling of the unpacked product it is advisable to use appropriate eyebolt in products suitable for this, with particular reference to the fact that this tool is intended to lift just the product itself and not the overall machinery with it related. If not, unpacked products over Kg. 30 and not supplied with eyebolts must be lifted and handled through cranes/hoists and sling.</p>
---	--

## 3. STORAGE

To properly store gearboxes/variators/bevel gearboxes it is necessary to follow these instructions :



- avoid storage outdoors or in presence of dust, damp and vibrations.
- store the product on shelves detached from ground level to avoid direct contact with the ground.
- should product be unused for a long time in a damp place ( RH over 50 % ) we recommend you to fill it up with oil and replace the ventilation plug with a closed one. When the product is used again the recommended original oil level will have to be restored. Please see the chapter about maintenance.
- when storing for long time periods we recommend you to protect machined parts ( shafts, surfaces, flanges ) with specially protective chemical compounds to avoid oxidation. It is also recommended to occasionally make gears turn to prevent damages on bearings and seals.
- in chemically aggressive environments it is necessary to protect the product with special paint and antioxidant products. Please contact STM SpA personnel to obtain additional information. If in presence of severe temperature differences, always provide hygroscopic pads and, in all cases, perform frequent checks.

## 4. INSTALLATION

### 4.1. PRELIMINARY WARNINGS – ENVIRONMENTAL CONDITIONS

Product mechanical maintenance or installation and start up operations must be carried out by qualified personnel. Incorrect installation of the gearbox may endanger the worker's safety and cause irreparable damage to the device itself and the machine to which it is connected. Follow strictly the following instructions. Should static or dynamic irreversibility be requested on wormgearboxes it is necessary to use brakes since complete irreversibility is impossible to obtain and maintain.

	Torque limiter, upon request on wormgearboxes, can not be considered a safety device in any way but only a protection device for mechanical parts/components. If the product must be painted, protect the machined surfaces and oil seals/gaskets in order to prevent any further damage. It is also necessary to protect the identification plate, the oil filter plug ( if fitted ) and the hole in the ventilation plug ( if fitted ) against obstruction.
---	---

  	<p><b>SAFETY COMPULSORY WARNING</b> for resetting the unit running after storage or unit reconditioning.</p> <ul style="list-style-type: none"> <li>To guarantee correct gearbox installation the working environment will have to be previously evaluated according to ATEX prescriptions and norms and, for example, all indications given in norms EN1127, EN60079-10 and EN50281 regarding Ex classification of environments and related risks. In alternative, appropriate protections and environmental monitor activities must be carried out so that similar microenvironmental conditions can be achieved in the area where the product operates.</li> <li>The evaluation or the specifications above given must be compatible with the ATEX Family and Type declared by STM SpA ( II 2G/D, see par 1.2) and mentioned on the nameplate. Without verification or in presence of verification with negative result installation and operation are forbidden.</li> <li>Carry out all set running activities in absence of potentially explosive environment.</li> <li>Clean appropriately all machined surfaces ( shafts, fanges, etc. ) to eliminate all protective elements used for the product storage as well as dirt and polluting substances.</li> <li>During these activities prevent thinners from mixing together in order not to alter the product specification and damage the efficiency.</li> <li>Make sure not to damage the product and not to load the product more than max. admittable toque value lindicated on the nameplate.</li> </ul> <p>In case oil used for storage is not compatible with the synthetic lubricant it is necessary to carry out a thorough cleaning inside the gearbox prior to fill it up with oil recommended for operating ( quantities and types as per STM catalogue ).</p> <p>Prior to connect the product it is advisable to check if any part have been damaged, if oil leakage have taken place or if there are any other signs of unconformity.</p>
---	--

Before carrying out any operation on the product make sure to protect from unusual events taking place as well as ensure that the drive system or motor is disconnected from the its main power source. In addition, it is necessary to prevent motions given by reversibility given, for example, by loads applied to the mechanically connected machinery. In any case, this kind of mechanical risks ( and similar ) must be faced by the installer in legal conformity with the destination/incorporation.

### 4.2. INSTALLATION

Incorrect installation of the gearbox may endanger the worker's safety and cause irreparable damages to the device itself and the machine to which it is connected. Strictly follow the below given instructions. The risks related to the use must be evaluated by the operator in terms of impact on the machine on which the device is to be installed. Do not arrange the product to be used :

- without a suitable lubricant compatible with working temperature and in overload conditions ( see catalogue )
- immersed in watery or corrosive environments
- if even one component is missing

Installation must be carried out so as to leave enough space for regular checks and maintenance as well as grant adequate ventilation and heat dissipation. The product must be installed according to the assembly position indicated in the order. When handling products prearranged for eyebolts remember that it is only suitable for lifting the gearbox and not the whole machinery it is connected to.

Make sure that the fixing of the gearbox/variator/bevel gearbox to the load-bearing machinery is steady so to be able to eliminate any possible vibration and also make sure that the fixing is done between machined surfaces. Remember to use anti-loosening systems for the fixing bolts.



Take special care to align the device to the motor and the machinery to be driven by fitting in between flexible or self-aligning couplings wherever possible. In the event of prolonged overloads, shocks or jamming risks, just install motor cut-outs, torque limiters, hydraulic couplings or other similar devices ( couplings and ( similar ) devices before mentioned generally do accomplish with Ex safety needs and must be conform to ATEX norms for the working environment to be evaluated in function of the operating environment. Do not exceed the max applicable radial and thrust load values applied to fast and slow shafts. Assembly and disassembly should be performed with tie-rods and extractors, using the threaded holes in the heads on the top of the shaft. Ensure that devices/components to be assembled onto the gearboxes/variators/bevel gearboxes are manufactured in accordance with following tolerance levels : shaft – ISO H6, hole – ISO H7. Before starting up the machine, always make sure that the lubricant quantity, its viscosity, ventilation and level plugs are suitable to the gearbox mounting position and relevant working conditions. It is also important not to use toxic oils and never mix different oil types. ( more in detail, if previously agreed with STM SpA technicians it is possible to replace a mineral base oil with a synthetic one, or vice versa, making sure that housings are completely drained, inner surface is thoroughly cleaned and gearbox is filled with oil according to the quantity and type mentioned in STM catalogue ).

**IMPORTANT !**

	<p>On the mounting positions where a shaft turns vertically and the oil shaking during operation might not sufficiently lubricate upper bearings, special solutions have been carried out such as shielded bearings, different oil levels, etc. to enable proper operation. Therefore, <b>it is always necessary to state the mounting position in the order</b> and to verify during the installation that the mounting position on the nameplate is in conformity with what requested.</p> <p><b>N.B.</b> on gearboxes <b>RI/RMI28, 40, 50, 63,70, 85 and CB/CR 40, AM/AR25, AM/AR32/1 and OM/OR63</b> the mounting position is not important since adequate lubrication is guaranteed in every mounting position. On different gearboxes, in case the mounting position indicated on the nameplate would differ from the one needed, consul STM SpA to perform the corrective actions before operating the unit. When mounting an output flange with a going-through threaded hole onto the gearbox, make sure to use appropriate length ( if necessary contact STM SpA ) for the screws in order not to leak lubricant. When the gearbox is fixed to the application through the torque arm, pay attention to the assembly to prevent structure to become hyperstatic.</p> <p>If a running test is carried out without load before installation ( the gearbox/variator/bevel gearbox does not transmit motion to other devices ) make sure that the key does not pop out from the shaft and injury operators or drag in clothes. Always remove the key and arrange adequate shaft protection by staying clear of the moving parts and not wearing clothes having loose parts.</p> <p>Safety precautions are mainly to be used as examples and guideline to simply warn danger circumstance. Every preventive arrangement must be carried out by the operator intended in the global safety picture in any working environment and in conformity with current legislation. In the event of failure, high temperatures might be reached or lubricant may leak out. It is therefore necessary to equip the machine with all necessary preventive measures in accordance to machine operational characteristics.</p>
---	--

**IMPORTANT!**

In those cases following specific applications, it is necessary to mount a ventilation plug on top of the gearbox housing ( in the most difficult cases by adding an expansion box ) to prevent overpressure inside the gearbox. If necessary, contact STM SpA or any authorized dealer see website [www.stmspa.com](http://www.stmspa.com).

  	<p>Each gearbox certified as ATEX must follow the next items:</p> <ul style="list-style-type: none"> <li>▪ An electrical contact to earth or a metalical assembly compatible with a conductive earth driven structure.</li> <li>▪ Such a type of assembly able to protect from damages the level indicator , the oil cap and all elements regarding the lubricant maintenance (oil seal , oil plug etc.).</li> <li>▪ To verify the absence of elements such as: parasitic currents, catodical or any other else which could be detected by the gearbox. Specially in areas where could be present a leakage flux caused by a coupled electrical motor.</li> <li>▪ In case of a chemical reaction of atmosphere against the lubricator and its vapors, those must be previously fulfilled, in order to avoid explosive mixtures. Continuous controls and inspections must be carried out in very distant areas, far from those considered as potentially explosives. Any other solution should be preventing an accurate hardening and tendering of environment.</li> </ul> <p>On all gearboxes " ATEX " it is necessary :</p> <p>Coupling gearbox – electric motor :</p> <ul style="list-style-type: none"> <li>• Apply a layer of anaerobic sealing compound on the centering surface and side flange connection.</li> <li>• Apply some antigrip compound ( for example compound based on bisulfate of molybdenum ) on the motor shaft and inside the input sleeve hole.</li> <li>• Connect the two components and then seal the connection parts between motor and gearbox by using appropriate sealing compound.</li> </ul>
--	--



**4.3 INSTRUCTIONS FOR INSTALLING COUPLING**

**"UMI"**  
**"RMI .. G" "CRMI..G"**

SIZE	IEC	AY		BY	dY	EY	LY
40	71	< 6		20	14	30	16
50	80	< 6		30	19	40	20
63	90	< 6		40	24	50	20
75	100 - 112	< 6		50	28	60	25
90	100 - 112	< 6		50	28	60	25

**"SM"**

SIZE	IEC	AY		BY	dY	EY	LY
25	80	< 6		30	19	40	20
35	90	< 6		40	24	50	20
45	90	< 6		40	24	50	20

Tab with size LY to STM drawing. The gearboxes in the PAMs shown on the table are supplied with the bushing + tab kit.

N.B. If the motor is not supplied by STM, check height AY shown on the table:

- 1) if the height measured is less than or equal to the height shown on the table, proceed to assembly.
- 2) if the height measured is greater than the height shown on the table, you have to assemble a tab with a smaller size LY.

**FASI DI INSTALLAZIONE:**

A) Assemble part 2 on part 1.

B) Assemble part 3 on the gearbox.  
 C) Apply a film of grease.  
 D) Assemble part 1 on the gearbox and tighten the fixing screws.

Contact our Technical Dept. for more information



#### 4.4. OIL FILLING

Gearboxes supplied by STM SpA already lubricated with synthetic oil do not need any further lubrication. On gearboxes supplied without lubricant but equipped with breathing, level and drain plugs it is necessary to provide and look after a correct lubrication as indicated on STM general catalogue.



Before installing the gearbox make sure to apply the breathing plug supplied alongwith the gearbox ( only where indicated ) in the correct position corresponding to the assembly position.

Mechanical speed variators are supplied filled up with lubricant ( please see general catalogue ). Correct lubrication is extremely important to have good performance of the variator. For this reason it is necessary to replace oil after the first run in session ( 200 working hours ) and after that every 1.000 working hours, always checking correct quantity through the level plugs.

	Do not forget that oil base must be synthetic as this improves performances and lifetime of the gearbox and bevel gear in comparison with standard lifetime. Synthetic oil, in fact, increases efficiency, enable longer lubricating performances and higher viscosity index. STM spa prescribes the following level of viscosity depending on each environmental temperature:
---	--

ISO VISCOSITY OF SYNTHETIC OIL					
460	320	220	150		
+10 °C +60 °C	0 °C +50 °C	-5 °C +35 °C	-10 °C +25 °C		
<table border="1" style="width: 100%; border-collapse: collapse;"> <tr> <td style="width: 10%; text-align: center; vertical-align: middle;">  </td> <td>           STM gearboxes, speed variator and bevel gearboxes supplied with or without lubricant can be used, unless differently specified, with environmental temperature between 0 and 50 °. In case of different environmental conditions please ask our technical office.         </td> </tr> </table>					STM gearboxes, speed variator and bevel gearboxes supplied with or without lubricant can be used, unless differently specified, with environmental temperature between 0 and 50 °. In case of different environmental conditions please ask our technical office.
	STM gearboxes, speed variator and bevel gearboxes supplied with or without lubricant can be used, unless differently specified, with environmental temperature between 0 and 50 °. In case of different environmental conditions please ask our technical office.				

	<p><b>È importante che gli additivi E.P. presenti negli oli siano blandi e non aggressivi nei confronti del bronzo e delle guarnizioni. La lubrificazione a grasso è consigliata solo con grassi a base sintetica e molto fluidi (NLGI 00); è preferibile per esercizi con urti elevati e per funzionamenti intermittenti.</b></p> <p>Using the grease instead of oil could produced a lower level of heat enamelling , a reduction ratio, a waging increasing and a lower level of lubrication in all components.</p> <p>Don't ever mix two different kind of oils. If there is a change of oil, it must be washed the house very accurately with a proper solver before the fulfilling <b>It is important for the E.P. additives in the oil not to be aggressive to bronze and gaskets. Grease based lubrication is recommended only by means of synthetic based or very fluid type of grease ( NLG100); it is recommended for duties where high shocks and intermittent operation are possible.</b></p> <p><b>IMPORTANT !</b></p> <p>On gearboxes where it is necessari to mention assembly position ( see general catalogue, chapter " lubrication " ) just verify when receiving goods or before product installation if this is the same as reported on the product nameplate. If not, get immediately in touch with the seller.</p>
---	--

 	<p>Gearboxes : <b>RI/RMI 28, 40, 50, 63, 70; CB/Cr 40, 50, 70; AM/AR 32/1,40/1, 50/1, 60 /1; AM/AR 25, 32, 40, 50; OM/OR 63; PM/PR 63</b> are regularly supplied lubricated and are delivered without servicing plugs to check oil quantity; it is necessary to periodically verify presence of oil leakages from oil seals or gaskets. In case of leakages, stop the gearbox immediately and contact STM SpA.</p> <p>On al other gearbox types the oil quantity check must be done through the appropriate oil level plug.</p> <p>It is forbidden to unscrew the oil plug in the models lubricated for life ( also noticed on the sticker near the plug ).</p> <p>When filling in for the first time, or for any other gearbox filling, please use the quantity shown in the catalogue.</p>
--	--

## 5. SET UP - OPERATION

### 5.1. GENERAL INSPECTION BEFORE SETTINGUP THE PRODUCTS

- Check up of the product assembly and correct axis alignment.
- Check up of the lubricant, its correct viscosità and quantità.
- Check breathing plug ( if to be supplied )
- Check up of the external applied loads.
- Check the output speed.
- Check up of the housing temperature during full load operation.
- Check up of the vibrations and noise level in operation.
- Check up of the oil seal tightness in operation.
- Check up of the operation adjustment devices ( torque limiter ).



	Do not put in operation the gearbox/speed variator/bevel gearbox in case it shows damages or defects affecting safety and operative features : repair and disassembly interventions must be carried out by authorised Service Centers ( which addresses are available in the relevant section on the website : <a href="http://www.stmspa.com">www.stmspa.com</a> )
---	---

	Do not apply shocks to shafts as it may damage the inner bearings. The external surface of the gearbox/speed variator/bevel gearbox may reach high temperatures ( above 70 ° ). Keep these risks in mind according to the usage, type of environmental conditions and climate in which the product will be used.
---	---

	During run - in period : keep the output speed under control, check vibrations, noise level and housing temperature not to reach too high values. Check the oil seal and gasketing tightness. It is essential to carry out these checks, as well as a gradual load application, in order to make the speed variator work right. In case of bad performances just stop the electric motor immediately and get in touch with STM SpA.
---	---

During operation it is needed to face the risks potentially caused by rotating parts as outlined in par. 1.4, to check every adjusting device involved ( torque limiter ), to check the operation temperature, noise level and oil seals and gasketing tightness. Check, wherever possible, if the lubricant is enough through appropriate oil level plugs. In case of mechanical speed variator, the speed adjustment can only be carried out while product is operating. No torque overvalues compared to nominal level are allowed.

	Should uncorrect operation take place ( differently from previously indicated circumstances even after having carried out all controls ) then please contact STM SpA authorised Service Center.
---	---

  	<p>Installation of " ATEX " gearboxes</p> <ul style="list-style-type: none"> <li>• In order to guarantee that gearboxes are installed correctly it is needed a previous verification of the operation environment following ATEX prescriptions and, for example, all indications as per norms EN1127, EN60079-10 and EN50281 concerning Ex environmental classification and relevant risks. In alternative, it is needed to carry out appropriate procedures and environmental controls so to guarantee similar microenvironmental conditions wherever the product is installed.</li> <li>• The evaluation or the preparation above described must satisfy the ATEX Group and Category type declared by STM SpA ( II 2G/D, see par. 1.2 ) and mentioned on the nameplate. In absence of verification or in presence of negative result the installation and operation of the product is forbidden.</li> <li>• Carry out the operation procedure in absence of potentially explosive environment.</li> <li>• Clean appropriately all machined surfaces and parts ( shaft, flanges, etc. ) and remove all protective compounds used for the product storing. Also remove impurities and toxic compounds.</li> <li>• During these operations avoid to get the thinners used for the cleaning and the oil seals in touch as this might alter the product peculiarities and jeopardize the efficiency of the product.</li> <li>• Avoid to apply any shock and mechanical stress over maximum capacity noted on the nameplate.</li> <li>• If the type of lubricant used for the storage is not compatible with the synthetic lubricant it is needed to carry out an accurate inner gearbox cleaning before filling it up with the oil suitable for the operation ( quantity and type as described on the catalogue ). During oil filling make sure that nothing else contaminate the gearbox.</li> <li>• Before assembling the gearbox make sure that there is no damage on any component, no oil leakage takes place as well as any other non quality conformity feature occurs.</li> <li>• Make sure that during operation no mechanical parts external to the gearbox are in touch with the gearbox. In case this happens, make sure to use non metallic anti-friction components in conformity with ATEX 94/9/CE norms.</li> <li>• Guarantee correct parallelism between output shafts and the transmission components connected as well as the perpendicularity between flange fixing surface/feet with output axis.</li> <li>• Make sure that the area around the gearbox is enough to grant proper ventilation ( supports, covers and similar devices as well as restricted environments might easily interfere with adequate heat dissipation and consequently increase the surface temperature over the maximum applicable values ).</li> <li>• Make sure that during operation there are no external elements which might damage the seals of the gearbox so threatening the correct oil retention inside the gearbox.</li> </ul>
--	---



 **Before replacing lubricant always make sure that the product has not been operated for at least 30 minutes, sufficient to let the temperature drop down not to be dangerous for the operator.**

 **In case of items lubricated with mineral oils always replace oil after 500-1000 working hours after a thorough inner clean up of the product.**  
 Never mix up synthetic and mineral oils; before replacing oils always clean up inner part of the product by using whether an appropriate thinner or similar oil type. Used up oils do need proper recycling ( see par. 1.5)

**In the following chart the lubrication times are listed referring to gearboxes operating under regular and continuous duty.**

LUBRICATION INTERVALS (h)		
OIL TEMPERATURE	MINERAL OIL	SYNTHETIC OIL
< 60 °C	4000	For life
60 – 90 °C	2500	10000



- Make sure filling and drain plugs are correctly closed ( monthly )
- Make sure to clean the gearbox/speed variator/bevel gear externally in order to remove dirt preventing regular heat dissipation.
- Monitor frequently temperature and noise level in the acceptable values.
- Check monthly if oil leakages take place.
- Check screw tightness at the end of the run in period and thereafter every 2.000 working hours.
- If the gearbox remains for a long time without being operated in a highly humid environment ( for example RH beyond 50 % ), just fill it up completely with oil. Obviously before operating the gearbox again it will be necessary to adjust the lubricant level.

The lifetime of the gaskets depends on many factors including the speed, temperature and environment so it can vary between 4.000 and 10.000 working hours.

 At the end of every intervention:

- Reset the product in the initial conditions as well as the safety arrangements as indicated at the par. 4.1
- Clean up the product accurately as indicated in par. 4.1
- Tap the oil plugs if any.
- Reset all the static seals by using appropriate sealants as indicated in par. 4.1
- Follow the procedure as in our par. 5.2 to operate the gearbox.



**6.3. SPARE PARTS – AFTER SALES SERVICE**

 Operations of disassembling and assembling of the gearbox/speed variator/bevel gearbox are very delicate and must be performed by STM SpA authorised Service Centers ( list available on our website : [www.stmspa.com](http://www.stmspa.com) )

**6.4. ROTTAMAZIONE / STORAGE – RECYCLING**

For a temporary or long time storage of the product make reference to the storage section indications.  
 Before recycling the gearbox/speed variator/bevel gearbox the lubricant must be drained out keeping in mind that dirty oil is highly polluting.  
 As far as recycling of the product is concerned, please consider following materials and elements contained : cast iron, iron ( Fe ), aluminium ( Al ), bronze, lubricant, rubber, plastic.  
 As far as transportation is concerned see the chapter relevant to logistics.

**7. PROSSIMITI e Locked shaft detector - RDB**  
 (This Accessorie is available for RMI - CRMI - CB)

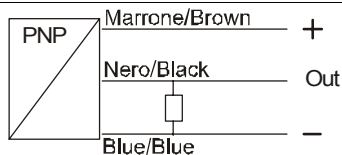
**TECHNICAL CHARACTERISTICS - DETECTOR**

Nonschermato-Unshielded	•
Tensione di alimentazione - Supplyvoltage	10..30Vdc
Ondulazione residua-Ripple	< 10%
Corrente massima di carico-Maximumloadcurrent	200mA
Caduta di tensione-Voltagedrop	< 3V @200mA
Assorbimento-Powerconsumption	< 10mA
Ripetibilità-Repeatability	<2% della portata nominale nominal sensing distance
Isteresi-Hysteresis	< 10% Sn
Frequenza di commutazione-Switchingfrequency	1kHz
Protezione al cortocircuito-Shortcircuitprotection	Si - Yes
Led di segnalazione-Statusoutputled	Si - Yes
Temperatura di funzionamento-Workingtemperature	-25+70°C
Grado di protezione-IPrating	IP67 (conconnetto remontato - with connector mounted)
Connessione-Connection	2m Cavo - cable

**7.2 PROSSIMITI + Locked shaft detector - RDB**

It consists of an electronic device designed to detect and warn off a locked shaft in motorized gearboxes equipped with torque limiters. It is mainly composed of two parts: the sensor (a) which is built-in the gearbox (b) without any additional need of space and the electronic monitoring unit (c).

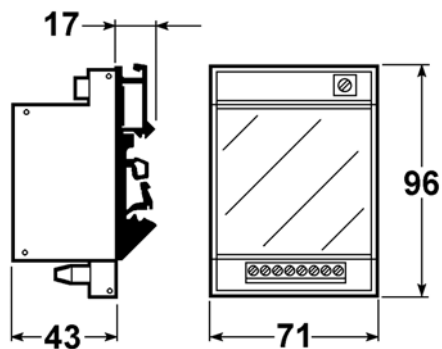
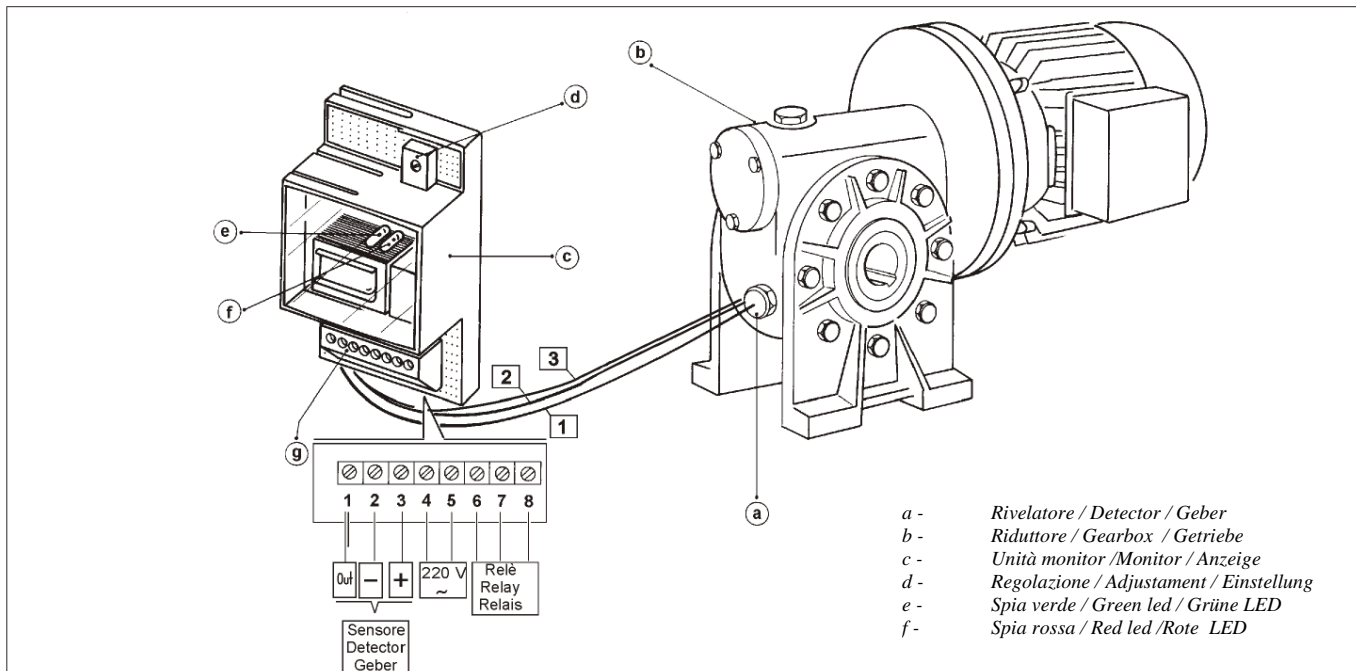

- g - Morsettiera / Terminal board / Klemmenkasten
- 1 - OUT - Sensore / Detector / Geber
  - 2 - Alimentazione Negativa Sensore / Negative Supply sensor
  - 3 - Alimentazione Positiva Sensore / Positive Supply sensor
  - 4 - Alimentazione c.a. 230 V. / Power Supply 230 VAC  
Spannungsversorgung 230V WS
  - 5 - Alimentazione c.a. 230 V. / Power Supply 230 VAC  
Spannungsversorgung 230V WS
  - 6 - N.C. / Normally closed / normalerweise geschlossen
  - 7 - N.A. / Normally open / normalerweise offen
  - 8 - Comune / Common / Sicherheitsleiter

The sensor generates a digital discontinuous electronic signal at a frequency which is proportional to the rotational speed of the output shaft of the gearbox; every time the signal is not generated, the electronic unit activates an output relay, highlighted by means of a red led, that warns off the condition of locked shaft. The contact of the above relay may be used to activate an alarm that starts an automatic shutdown procedure or simply cuts off power to the motor which drives the locked gearbox.

As mentioned above, the sensor generates a discontinuous repetitive signal.

This is particularly important in all those applications characterized by low output speed since the time interval between the impulses generated by the detector could trigger detection of a locked shaft condition which does not actually exist.

In order to prevent this possibility, the circuit can be programmed with a slight delay, according to motorization characteristics, to cover the signal repetition intervals without compromising the operating safety of the equipment.

Regulation of interval time (D) provided by the electronic unit can also be effected in order to impose a delay to the signalling of an actual locked shaft condition in all those cases where, during normal operation, sudden changes of speed or inertia or when there are temporary excesses in the load's resisting moment, could determine the intervention of the torque limiter with subsequent temporary stop of the shaft.

Such delay should obviously be adequately long to reset the normal operating conditions. In fact, if the shaft remains locked for longer than the set time, the condition is detected and signalled to the equipment.

The limiter has actually a memory function which is used to prevent the locked shaft condition from being cancelled even if the gearbox resume rotation and it is highlighted by means of a red led.

**Operating conditions:**

Unit operating temperature: 0° , +50°C

Storage temperature: -20° , +70°C

Voltage supply : 220V (+30V , - 40V)

Intervention time:

0.2 sec. min.

8 sec. max.

With reference to the interval duration it is important to consider that the minimum slippage which can be detected with standard sensor is 25° when rotation speed permits enough time to carry out the slippage.

Minimum number of detected turns: 0.4 min<sup>-1</sup>

The sensor is supplied, if not specifically requested, with a not shielded cable: it is recommended to replace it with a shielded one.

About use and installation of the locked shaft detector, see the instruction enclosed to device box.

**8. VALIDITA' DEL DOCUMENTO E INDICE DI REVISIONE**

**8. VALIDITY AND REVISION INDEX**

This booklet cancels and replaces all past editions and revisions. STM reserve the right to modify it without previous notice. In case this document is distributed to you in a non – controlled way, it is not ensured that all datas herewith contained are updated. In such a circumstance, check in our Web Site: <http://www.stmspa.com>.