



ELECTRONIC SPEED VARIATOR

New Intelligent Systems

User's Manual



S.T.M. S.p.A.

Via del Maccabreccia, 39 I 40012 Lippo di Calderara di Reno (BO)

T: 051/64.67.711 F: 051/64.66.178

URL: www.stmspa.com E-MAIL: stm@stmspa.com / service@stmspa.com

User's Manual

1. GENERAL INFORMATION	3
1.1 Manufacturer and machine data	3
1.2 Guarantee and service conditions	4
1.3 Used symbology	4
1.4 Safety global aspects	4
1.5 Responsibilities	5
2. MACHINE DESCRIPTION AND TECHNICAL DATA	6
2.1 General description	6
2.3 THREE PHASE ESV DATA SHEET	7
3. TRANSPORT, HANDLING, STORING	7
3.1 Warnings	8
3.2 Transport, packaging and handling.	8
3.3 Deposit and storing	9
4. INSTALLATION	9
4.1 Warnings	9
4.2 Environmental using conditions	9
4.3 Necessary place during the functioning	10
4.4 Placing and installation on the spot	10
4.5 Connection to the sources of energy	11
4.6 Installation	12
5. MACHINE USE	12
5.1 Warnings	12
5.2 Safety systems.	12
5.3 Control, regulation and signalling systems	13
5.3.1 Start up and stop	15
5.3.2 Speed rotation regulation	15
5.3.3 Ramp regulation acceleration	15
5.3.4 Movement enabling	16
5.3.5 Selection of the direction.	16
5.3.6 Wiring braking resistance.	16
5.4 REMOTE CONTROL INTERFACE FOR ESV-CONNECTORS INPUT OUTPUT OPTION JUMPER SELECTION	17
6. DIAGNOSTIC AND INTERVENTION	19
7. MAINTENANCE	20
7.1 Warnings	20
7.2 Cleaning and ordinary maintenance	20
7.3 Periodical inspection	20
7.4 Replacing of bearings or other spare parts.	21
8. PLACING OUT OF SERVICE	21
9. Appendix	21
9.1 Motopotentiometer Menu	21
9.2 Display Menu	21
9.3 Frequency Menu	23
9.4 Commands Menu	23
9.5 Parameters Menu A	24
9.6 Parameters Menu Ab	26
9.7 Functional description	28
9.8 Frequency reference setting	28
9.9 Setting of motor voltage/frequency characteristic	29
9.10 Frequency jumps - Output frequency limitations - Jogging - Switching frequency - Accel. and decel. ramps	30
9.11 Motor data setting - Motor thermal protection - Prevention of motor stall - inverter lock	31
9.12 Slip compensation - Instantaneous overload signalling - Prevention of short mains blackout - Pickup of motor in free rotation (flying restart) - Automatic boost	32
9.13 Programmable control inputs	33
9.14 Auxiliary analog input (AUX-V) - Analog output (OUT-AN)	34
9.15 Programmable digital outputs	35
9.16 Dynamic braking - Direct current braking.	36
9.17 PID regulator	37
9.18 Reset - Autoreset - Protections and alarms	38
9.19 Auxiliary Keyboard - Programming Key- Remotation cables of signal command	40

1. GENERAL INFORMATION

1.1 Manufacturer and machine data

Manufacturer: S.T.M. Spa - Via del Maccabreccia, 39
 I 40012 Lippo di Calderara di Reno (BO)
 T: +39/051/64.67.711 F: +39/051/64.26.178
 URL: www.stmspa.com
 E-MAIL: stm@stmspa.com / service@stmspa.com

Model and serial number : model, serial number and main characteristics of the device are placed on the product identification plate, on the top of the cover of the control box (fig. 1.3). In fig. 1.1 it is showed the place of the electric motor, while in fig. 1.2 it is showed a representation of the plate itself and of the different descriptive fields .

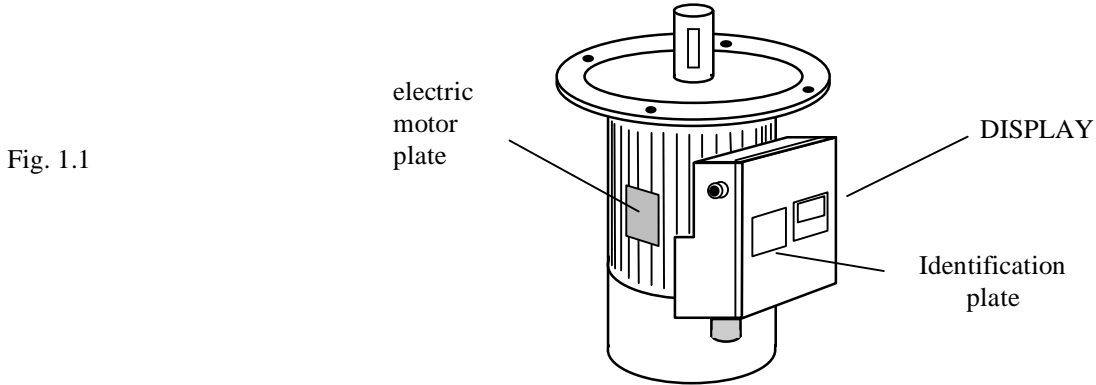

Fig. 1.1



 STM BOLOGNA-ITALY CE					
Tipo			Nr.		
Prot.IP		Serv.		Cos.φ	
Is. Cl.					
V Δ/Y	Hz.	HP	KW	min-1	A Δ/Y
Motore asincrono					

Fig. 1.2



ELECTRONIC SPEED VARIATOR



BOLOGNA-ITALY
 T +39/051/64.67.711
www.stmspa.com

TIPO ESV 05 4TS 71B4 B5	CODICE 2502710081
TYPE	CODE
ALIMENTAZIONE 400V 50/60 HZ	DATA 06/00 NUMERO 376.2000.A
SUPPLY	DATE NUMBER

ATTENZIONE:

- APPARECCHIATURA SOTTO TENSIONE ANCHE A COPERCHIO APERTO
- CONDENSATORI CARICHI
- PRIMA DI RIMUOVERE IL COPERCHIO INTERRUPERE L ALIMENTAZIONE ED ATTENDERE ALMENO CINQUE MINUTI

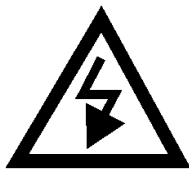

CAUTION :

- REMOVING COVER EXPOSES DANGEROUS LIFE PARTS
- CHARGED CAPACITORS INSIDE
- BEFORE REMOVING COVER DISCONNECT DEVICE FROM MAINS AND WAIT IN EXCESS OF FIVE MINUTES





Fig.1.3

1.2 Guarantee and service conditions

The guarantee conditions and modalities to refer to are the ones indicated on the backside of the transport document. If authorised service is required please ask the supplier.

1.3 Used symbology

Hereafter follows the list of the conventional symbols used in the present manual with relative explanation.

SYMBOL	DESCRIPTION
	GENERAL DANGER It signals to the personnel that the described operations could cause accident, if not made in the respect of the indicated safety norms.
	ELECTROCUTION DANGER It signals the interested personnel that the described operation could cause electric shock or other electric damages if not made in the respect of the indicated safety norms.
	FIRE DANGER It signals the interested personnel that the described operation or circumstance could cause fires.
	PERSONAL PROTECTION This symbol requires the use of personal protections to the operator while making the described operations.
	N.B. It signals to the interested personnel important information about the management of the machine.

1.4 Safety global aspects

 This manual contains important information to avoid that incorrect use of ESV causes danger to people or things. Carefully follow the instructions during the installation and use phase of the device.



Before installing ESV check to have received the right model by carefully reading the information on the device plate; see description at point 1.1. If a wrong model was delivered, immediately contact the supplier.

The ESV presented in this manual is an electric motor with a variable speed, to be used on a machinery and supplied by electric line.

The above machineries could be dangerous for the users/operators, both as for the electric supply and for the handling of electrical organs. Consequently, before starting the machinery described in this manual (hereinafter called «ESV») it is compulsory to carefully follow instructions in this manual.

ESV installation and use must be made by qualified personnel for mechanical and electrical operations on the machinery.

Immediately inform the supplier of eventual damages during the transport: in this case do not start it.

Keep these instructions in a safe place.



All adjustment operations of internal parameters which provide for the access to the control box must be made with no supply of electric energy and after having waited at least five minutes from all phases disconnection before removing the cover from the control box.



- No modification of any kind must be made to the machinery
- The components of the machinery (motor, control box, electronic cards, etc.) must not be disassembled
- Do not put any kind of object inside the control box
- Inside the system there are no repairable or upkeepable parts from the user. In case of breakdown switch the machine of the supply and contact the authorised service

1.5 Responsibilities

S.T.M. Spa undertakes no responsibility for consequences and damages caused by the non respect of what expressed in the present manual.

It is user's competence and responsibility to determinate the risks and find out the adequate safety norms of the system on which ESV is installed .

This technical documentation (MUM - ESV/S-EXTENDED -rev. 2 dated 7th of may 2003 - extract from NORM 0186) cancels and substitutes each previous edition and revision. We reserve the right to modify the above mentioned documentation everytime it will be necessary.

If you do not receive this document by means of a controlled distribution, its updating won't be assured. In order to verify whether this is the last version, do not hesitate to contact STM Sales Dept.

2. MACHINE DESCRIPTION AND TECHNICAL DATA

2.1 General description

Here below are listed ESV main characteristic in a normal continuous functioning cycle:

- Continuous variability standard of the motor rotation speed from 100 rpm to a 1500 rpm
- The maximum torque is constant like showed in fig.2.1
- ESV is equipped with a series of electronic protections enabling to temporarily exceed the normal functioning limits. Particularly:

It is possible to set the working point between 100% and 200% of the nominal torque, if the requested power is lower than the nominal one (in single phase models for a time not exceeding one minute: after that the immediate block will happen); over a certain time-limit the system could go in over-temperature alarm and block

Over this time the system could go into alarm for over-temperature and block

- If the requested torque exceed the 200% of the nominal current ESV will block immediately.

In Fig. 2.1 it is showed the mechanical characteristic, with 4poles motor, with indications of the working areas admissible in a continuous or discontinuous way

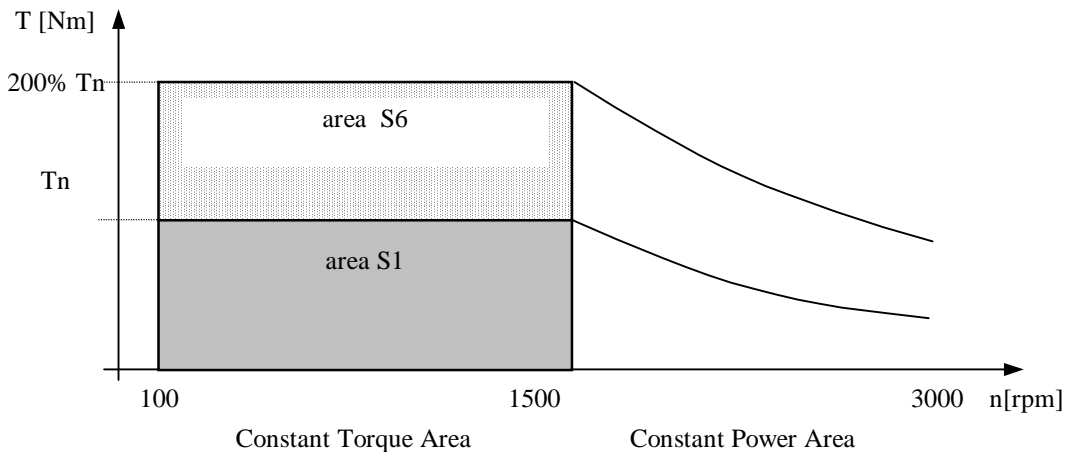

T [Nm] torque

T_n [Nm] nominal torque

T_s [Nm] distributable torque in continuous service (S1)

T_{max} [Nm] maximum torque supplied with the 200% of nominal current applied to the electric motor

Area S6 overload discontinuous service



Please note the system will block immediately: the electronic control let the shaft free to turn and it is necessary to check the effects.



ATTENTION : the ESV is not a safety device.

Fig. 2.1

Fig. 2.2 shows a schema of ESV and its main components.

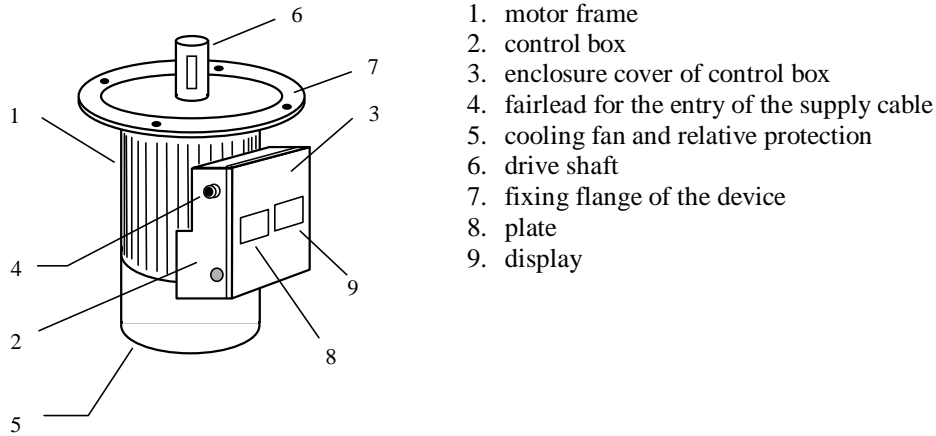

1. motor frame
2. control box
3. enclosure cover of control box
4. fairlead for the entry of the supply cable
5. cooling fan and relative protection
6. drive shaft
7. fixing flange of the device
8. plate
9. display

Fig. 2.2

The electronic speed variator is given by an electric motor which is controlled by an electronic circuit.

The control keyboard allows the user to easily and quickly enter any parameter necessary for the required working conditions.

The threephase, variable frequency, alternate voltage, controlled by microprocessor, is delivered to the motor through a power module which uses the most recent IGBT technology.

The use of microprocessor, IGBT technology and modulation frequency programming, assures an extremely accurate and silent operation.

The software, properly developed for power electronics, allows for an accurate and quick control of motor speed, start and stop times which can be independently adjusted, and other operation conditions:

- Speed control as a function of the load is by current adjustment, thus allowing for automatic adjustment to process.
- Automatic boost that allows for a safe start of the motor by acting on the torque as a function of the load. Presence of high torques and rotation evenness at very low frequencies too.
- Direct current braking, with programmable duration and value, allowing for a comfortable motor stop.
- Presence of a standard series line, with programmable transmission modes, to remote program and/or control the converter.

2.3 THREE PHASE ESV DATA SHEET

Mechanical and environmental characteristics

	ESV 05	ESV 10	ESV 15	ESV 20	ESV30	ESV40	ESV50	ESV75	ESV100
Pn	0,37 kW	0,75 kW	1,1 kW	1,5 kW	2,2kW	3kW	4kW	5,5kW	7,5kW
Tn [Nm]	2,5	5,0	7,4	10,0	14,7	20	27	37	49
Ts	from zero to nominal torque								
Te	Up to 200% of nominal torque								
Tmax	200% of nominal torque								
N	100 1500 rpm								
Δn	100 from T=0 up to Tn								
T [C]	0 - 40								

Electrical characteristics

	ESV 05	ESV 10	ESV 15	ESV 20	ESV30	ESV40	ESV50	ESV75	ESV100
Supply	Threephase A.C.: 380V-15%, 460V+ 10 % , 50/60 Hz								
In [A] rms	2,1	3,5	5	6	8	10	13	16	21
EMC	Integrated								
IP	IP55								

- Pn [KW] nominal power
- Tn [Nm] nominal torque
- Ts [Nm] deliverable torque in continuous service (S1)
- Te [Nm] deliverable torque overload condition (S6)
- Tmax [Nm] maximum torque
- n [min⁻¹] speed
- Δn [min⁻¹] maximum speed error
- Jmax [kgm⁻²] max. moment of inertia of the load
- T [C] temperature
- In[A] nominal current
- EMC line filter EMC
- IP protection of equipment respect to solid and liquid

3. TRANSPORT, HANDLING, STORING

3.1 Warnings



The transport and handling of the product both packed and unpacked can be risky for the operator for the machine weight (see paragraph 2.2.1) and its mechanical characteristics.

3.2 Transport, packaging and handling.

Transport the machine only if carefully packaged and sheltered from shoves, dust and dirty.



Before moving or packaging the machine, control box cover is correctly closed and screwed and can grant a good mechanical protection to the inner electronic card.



The handling of non packaged product, both manual and with handling systems, mustn't be made using as lifting point the control box or the metallic protection of the back cooling fan. Use only the frame or the attack flange of the motor.

The risks in ESV lifting and moving must be afforded by the user in relation to the different situations. If ESV weight more than 30kg , it is necessary to use an adequate lifting device.

3.3 Deposit and storing

To deposit and store the packed product please follow the above specifications.

ESV	05TS	10TS	15TS	20TS	30TS	40TS	50TS	75TS	100TS
Maximum number of stackable packaging	2								
Deposit environmental conditions	Temperature: from 10 to +80 C; Absence of condensation ; Lack of dust and vibrations								
Weight of packed product[kg]	9,5	13,7	17,5	21,8	29,8	32,4	39	63	65

MS = single phase standard

TS= three phase standard

4. INSTALLATION

4.1 Warnings



- The non correct installation of the device could be dangerous for the operator s safety and for the device itself. Carefully follow the assembly instructions below indicated and only refer to qualified electricians and installers.
- In case of bad functioning or system block the motor is automatically led into neutral state with rotor free to round; be careful not to cause danger, in relation to the using modalities of the machine on which ESV is assembled.
- The ESV are not designed to work as a brake for the load to which it is connected. If this should occur the system will block, leaving the motor in neutral state, with the rotor free to round. **Be careful not to cause danger, in relation to the using modalities of the machine on which ESV is assembled.**
- The risks of the ESV use have not to be related to the machine to which it will be assembled.

4.2 Environmental using conditions



The device external surface can reach high temperatures (higher than 60). It is recommended to evaluate the risks on the basis of the use, the kind of environment and the atmosphere in which the device will work.

The product is due to be connected to machines working in industrial environment.

The working conditions must be :

- Protection degree IP55
- Environmental temperature variable between 0 C and 40 C (near device) .
- Absence of condensation .
- Absence of caustic, inflammable atmosphere or at explosion risk.
- Height up to 1000m (above sea level) as for the data on the plate; at higher height the return power decreases of 9% every 1000 Mt.
- Vibrations that don t damage the electronic components



If the working environment is particularly dusty, it is recommended to periodically clean the ventilation system. (See Chapter 7, Maintenance)

4.3 Necessary place during the functioning

The functioning place of the device has to enable:

- A right ventilation of the motor and of the box containing the control electronic;
- An easy opening of the box upper cover and a good access to system inner regulations;

To satisfy the above specifications, it is necessary to have around the device the following place:

- Not less than 100 mm from the lateral sides of the motor's frames;
- Not less than 150 mm from the cooling fan back protection grille;
- Not less than 250 mm over the control box cover;

See fig. 4.1.

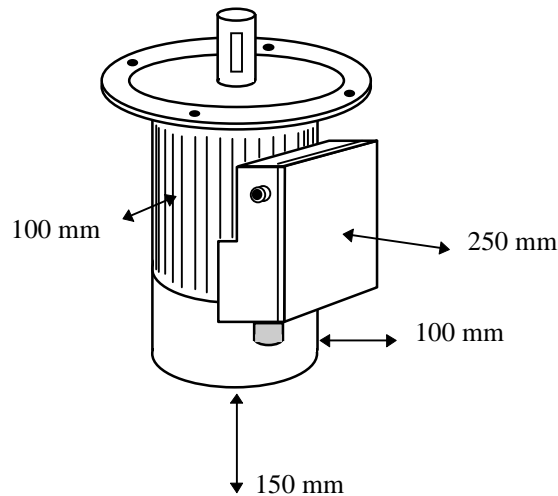

Fig. 4.1

If not possible to have distances like the ones above indicated, provide with an equivalent air volume and free circulation with external environment.



However this space should enable an efficient change of air, which is absolutely necessary for the system cooling.



If the working environment is particularly dusty, it is necessary to grant more space than the one indicated and sufficient to enable the periodically cleaning of the ventilation system. (See Chapter 7, Maintenance)

4.4 Placing and installation on the spot

To install ESV in the working position there are not other prescriptions other than the ones already quoted in paragraph 4.3, "Necessary place to the functioning".

The installing procedure is the following:

1. take off the drive shaft protection plug.
2. make sure, if allowed by the application, the device placing can grant an easy access to the command and inside regulation.
3. fix the system by using the motor attack flange (for types B5 or B14) or the frame motor feet (type B3).
4. make sure the fixing screws are correctly clamped.

4.5 Connection to the sources of energy

The system requires a supply voltage, alternating three phase 460V +10% 380V 15% and frequency 50Hz o 60Hz in relation to the data on the plate of the specific model.

For the measurement of the electric installation and of the protection switches to be placed in the device please refer to the following schema:

Tab.4.1

Model	In[A]	Slow-blow fuse [A]	Minimum section cable[mm ²]
ESV05TS	3,5	10	1,5
ESV10TS	3,5	10	1,5
ESV15TS	6	10	1,5
ESV20TS	6	10	1,5
ESV30TS	13	25	2,5
ESV40TS	13	25	2,5
ESV50TS	13	25	2,5
ESV75TS	16	25	4,0
ESV100TS	21	32	4,0



The indicated cable section is the thinnest one when their length does not exceed 30 Mt. In this way the line drop does not exceed 5% of the power voltage, as specified by the Norm EN60204-1.



If ESV is installed in an implantation with ground fault interrupter, this one should be calibrated for an intervention current **not lower than 100 mA** and for a time **not lower than 0,1 s**.



The ground fault interrupter should bear high frequency noise.

System electric connection procedure and preliminary check:

1. take the screw off and than the control box cover, being careful not to lose the screws and the gasket;
2. put the supply cable into the box by the proper fairled;
3. connect the ground connector to the box housing by the proper screw (indicated with the conventional ground symbol).
4. Connect the line phases to the terminal indicated with L1-L2-L3
5. Check that all the terminals are well clenched and the wires are steady blocked;
6. Steadily block the cable in its seat by clenching the fairled;
7. Check the motor power size is well set on the configuration switches of the electronics card.
8. Check that objects weren t left for chance inside the box;
9. Close again the box cover by correctly placing the gasket and carefully clenching all the screws;
10. Supply the system;
11. Check that the cooling fan work in the right way;
12. Switch the system off.



ESV must be connected to the sources of electric energy by respecting the rules in force about plant engineering and in the building (EN60204-1 on the machine).

4.6 Installation

The user/installer has the responsibility for the safety of his construction, according to the norms UE and national rules. The safety indications in this manual are due to this aim, but they are only about ESV and its use.

For over temperature and over loading see par. 5.2 and 6 .

 During the first test, start ESV with the plastic protection on the drive shaft, because the key can be thrown out for centrifugal force and cause huge damages.

While functioning check that the installation do not present too many vibrations. On the contrary, turn ESV off and verify that the coupled organs are well balanced and the base is solid. If while working ESV is too noisy, check the bearings are not weared and need to be replaced (par. 7.4).Contact service STM.

Before installing ESV it is recommended to check the general state; particularly check the right functioning of the mechanical organ, and most of all the rotation smoothness of the drive shaft.

Compare the technical data and the specifications on the allowed use in this manual, in the plate data and in any other documentation enclosed to the item with the right characteristics.

Respect the general indications about good manufacture and preventional technique, the local rules and the machine specifications.

Verify that all electric terminals in the terminal board are well connected, that the voltage and frequency value on the plate are the same of the power supply, from which ESV will be supplied. Otherwise the installation is forbidden.

5. MACHINE USE

5.1 Warnings



- It is recommended to use ESV exclusively with the control box cover correctly closed and screwed..
- The voltage levels inside the control box are **EXTREMELY DANGEROUS**. Before opening the cover, disconnect all the conductor phase of the system.
- Wait at least five minutes because the inner voltages reach value for the operator s safety.
- Make sure all led are switched off.
- When closing the control box and before supplying the system, make sure that objects weren t left inside it

The non respect of these safety norms could be very dangerous for the operator and cause irreparable damage to the system.



Do not remove the back protection of the cooling fan.

5.2 Safety systems.

ESV is provided with the following inner electronics protections:

- **Temperature protection for the electronics:** it causes the system block if the temperature inside the control box exceeds the allowed safety limit. This can happen if the system works over the nominal power of the motor, over the nominal torque
- **Protection of the maximum torque:** it causes the immediate block, if required to ESV a torque more than 200% than the nominal one.

- **Overloading protection:** it causes the system block if requested to ESV a couple which is able to absorb a current of 200% higher than the nominal one, for 30s each 20 min. (or equivalent). Give a look to the following picture.

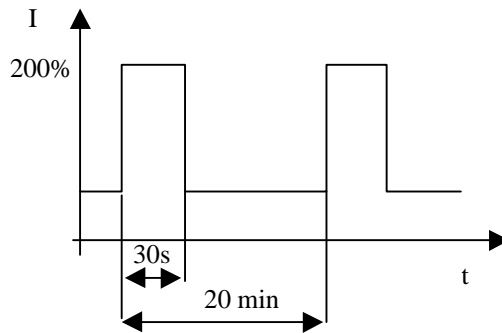

5.3 Control, regulation and signalling systems.

ESV control system has been designed by means of control signals available in the interface connectors and in the control keyboard.

Control keyboard and display

	<p>FWD Green led for forward rotation REV Green led for reverse rotation PRG Yellow led giallo for programming: if flashing it means that the parameter has not been recorded.</p> <p>M selection key E Enter key ↑ Increasing key ↓ Decreasing key</p>
--	--

Parameters Menu of the Electronic variators

d-xx Parameters Menu only for reading (Display of Electronic variator s status).Pay attention to appendix 9.2

F-xx Parameters Menu for reading and writing of frequencies to be selected from digital input. Pay attention to STM web site.

A-xx. Parameters Menu for reading and writing.

Ab-xx Parameters Menu for reading and writing: on-off type (To be modified only when the motor is not working).As regards the basic configurators, please, pay attention to the essential programming paragraph. On the other hand, as regards the complex applications it is necessary to download the documentation from STM web site.

C-xx Control parameters menu. Pay attention to STM web site.

Mt-xx Motopotentiometer s Menu. Pay attention to 9.1 appendix.

PARAMETER S MODIFING PROCEDURE

1. Select the parameter to be modified by means of M menu keys and arrows
2. Press the key enter E : it will be displayed the actual parameter.
NOTE: if the yellow led is on, you will go on modifying the parameter.
3. To modify the parameter it is possible to use the the arrow keys for increasing or decreasing the variable.

1. Press the key enter E to confirm the modified data. In order to escape the program without recording the modified data, press the key menu M and go back to the variable code.

MODIFICATION RECORDING PROCEDURE

Press the key menu M and select the menu C-xx

Select the code C-00

Confirm with enter key E. Pay attention to the fact that the recording is allowed only when the yellow led PRG is on. Select 7 with arrow keys.

Confirm with enter key E : it will be displayed runn followed by done , which means the procedure is ended.

ESSENTIAL PROGRAMMING

The ESV essential programming is described as followed.

For special application, please, download the the advanced programming manual you can find on STM web site. Below is described the elemental programming of ESV.

Menø parameter A-xx

Cod	DESCRIPTION	Variation field	Unit	Default
A.00	Rif speed programming	0-5	1	5
A.01	Maximum speed (set frequency point)	50/480	HZ	50
A.02	Minimum speed (set frequency supply point of electric motor)	-480/+480	HZ	4
A.03	Acceleration referring to A.02 parameter	0,01/9999	S	3
A.04	Deceleration referring to A.02 parameter	0,01/9999	S	3
A.05	Parameters protection (*)	0/2	1	1

(*) protezione parametri: 0 = Not modifying parameters

1 = Modifying parameters: A.00-A05 , Ab.00-Ab.04

2 = each parameter might be modified.

Parameters menu Ab: type on/off

Cod	DESCRIPTION			Default
Ab.00	Configuration of run- inversion comand input.	0=RUN/REV	1=FWD/REV	0
Ab.01	Direction	0=CW (clockwise)	1=CCW (counter clockwise)	0
Ab.02	Run comand contact security when putting on ESV.	0=OFF	1=ON	0
Ab.03	Stopping mode	0=with ramp	1= inertial	0
Ab.04	Reference Memory of motopotentiometer when putting off ESV. (*)	0=without memory	1=with memory	0

(*) speed memory:

0 : When you put on again the electric variator it is necessary to program again the speed

1 : Every time you Put on ESV the last programmed speed is recorded.

5.3.1 Start up and stop

OPERATIVE PROCEDURES

The setting up of A.00 e Ab.02 parameters produces four possible operative modes:

1. **MODE 01** : the configuration is as follows A.00=5 e Ab.02=0
 - Speed regulated from keyboard with arrow keys.
 - Automatic run-gear when starting 400V
 - Stopping because of inerzia when 400V stops.
2. **MODE 2** : the configuration is as follows: A.00=5 e Ab.02=1
 - Speed regulated from keyboard with arrow keys.
 - Automatic run-gear when remote contact stops.
 - When the remote contact starts working, ESV stops working.
3. **MODE 3** : the configurator is as follows: A.00=0 e Ab.02=0
 - Speed regulation depends on the remote potentiometer.
 - Automatic run-gear when 400V starts.
 - ESV stops because of inerzia when 400V stops
4. **MODE 4** : the configuration is as follows: A.00=0 e Ab.02=1
 - Speed regulated from the remote potentiometer.
 - Automatic run-gear when remote contact stops.
 - ESV stops when the remote contact starts.



Depending on the state of the system the start can immediately occur: after the connection to the power supply or a little bit late (less than two seconds), and necessary to start the electronics circuits initialisation.

5.3.2 Speed rotation regulation

Speed rotation regulation depends on the parameter A.00, as explained on following table .

Valore	Descrizione	Parametri associati
0	Speed regulation by means of analogic input REF-V (0/10V).	A.01,A.02,A.17, Ab.08
1	Speed regulation by means of analogic input REF-V(-10/+10V). The polarity causes the rotation direction.	
2	Speed regulation by means of REF-I (0-20mA se Ab.08=0 ; 4-20mA se Ab.08=1) analogic input.	
3	Speed regulation by means of digital inputs (see menu F)	
4	Control of Electronic Variator by means of serial line.	
5	Motopotentiometer: Speed regulation by means of arrow keys.	

5.3.3 Ramp regulation acceleration



Do not absolutely make system regulation operations with the box open and the device supplied.

The lasting regulation of the acceleration (and deceleration) ramp makes you able to obtain an increase or decrease the motor rotation speed.

- Threephase ESV: the acceleration lasting may be regulated as the A. 03 variable, on the other hand the deceleration may be regulated as the A. 04 variable.

Acceleration and deceleration ramp regulation s procedures:

Stop ESV and program by means of keyboard the requested value for A.03 e A.04 parameters;

5.3.4 Movement enabling



Do not absolutely regulate the system when the box is open and the device is supplied.

The run-gear key has to be considered as a motion permission or as function starting up of the device. This happens by means of an in-line switch or by means of a control signal, using the specific I01 interface cables, which are described later on.



The state of disabled device mustn't be considered as a safety one, in which operating special regulation or maintenance activities or other.

To reach a safety status, verify that all phase conductors to the system have been disconnected for at least five minutes.

5.3.5 Selection of the direction.



Do not absolutely make operations of system regulation when the box is open and the device is supplied.

The direction command can be realized by means of a remote key, using the REV signal of remote I01 cable or by means of Ab. 01 parameter.

5.3.6 Wiring braking resistance.



Do not absolutely regulate the system regulation when the box is open and the device is supplied.

Connect to the faston plug on the power schedule as underlined by the Rbr serigraphic writing. The minimum values are specified on the following scheme.

Model	Minimum limit of the braking resistance
ESV05TS/ESV10TS	100 ohm/200W
ESV15TS/ESV20TS	100 ohm/200W
ESV30TS/ESV40TS/ESV50TS	75 ohm/350W
ESV75TS/ESV100TS	50 ohm/600Watt / 25 ohm/600Watt

5.4 REMOTE CONTROL INTERFACE FOR ESV-CONNECTORS INPUT OUTPUT OPTION JUMPER SELECTION

Signals disposition on the connectors of the control card (generic male connector seen from above). Each connector is supported by a serigraphy which enable you to identify the connector itself. Each connector's pin is associated to a number, a signal and a colour as explained in the following charts:

LINK CONNECTOR FOR RS-485 SERIAL CONNECTION

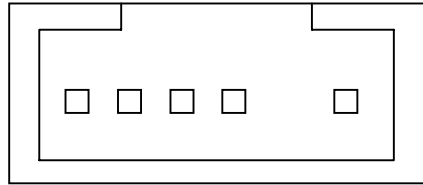

1 2 3 4 n

Pin	Colour	Signal	Function
1	White	+5V	
2	Red	LINK-	RS-485 Serial input
3	Green	LINK+	RS-485 Serial input
4	Black	0 V DIGIT	Digital Mass

DISPLAY CONNECTOR

An extension connection allows the display connection if the following indications are respected:

Pin	Colour
1	Pink
2	White
3	Yellow
4	Grey
5	Green
6	Brown

REMOTE CABLE IO1 SIGNAL

Pin	Colour	Signal	Function
1	Pink	10V	Potentiometer tension for speed reference
2	White	REF V	Speed reference
3	Yellow	0V AN	Common
4	Grey	24V, 300mA	Output for feed sensors
5	Green	RUN	Run input
6	Brown	REV o -10V	Inversion input/-10V for speed reference. Selection by means of jumper (see serigraphs REV/-10V)
7	Blue	IN 1	Configurable Digital input.
8	Red	OUT AN o OUT1	Analogic output 0/10V/Configurable digital output. Selection by means of jumper (see serigraphs O.A/O.D1)
9	Black	RELAIS	Relais contact for alarm signal .Selection
10	Violet		NO o NC by means of jumper (See serigraphs R.NO/R.NC)

REMOTE CABLE IO2 SIGNAL

Pin	Colour	Signal	Function
1	Grey-pink	OUT1	Configurable digital output
2	Red-blue	OUT2	Configurable digital output
3	White-green	IN2	Configurable digital input
4	Brown-green	IN3	Configurable digital input
5	White-yellow	IN4	Configurable digital input
6	Brown-yellow	AUX V or REF I	Configurable analogic input/Reference current input for speed reference (0-20mA o 4-20mA). Selection by means of jumper (See serigraphs A.RV/A.RI)

Note:

- The active digital outputs have to be considered as switches that turn to 0V, so that the charge has to be connected between +V and the output (Vmax=50V, Imax=50mA).
- The inputs are active if put at 24V.
- External fault (EF) funtion can be programmed by means of digital inputs. Jumpers you can find on the control card near to the connectors IO select some signals of IO.

In the following table you can find all possible configurations.

Jumpers you can find on the card near to IO connectors select some IO signals. In the following chart you can find all possible configurations:

Serigraphs	Signals
<i>REV/-10V</i>	Reverse/-10V
<i>O.A/O.DI</i>	Analogic Output / digital output 1
<i>R.NO/R.NC</i>	Usually open Relais contact / Usually closed relais contact
<i>A.RV/A.RI</i>	Auxiliary analogic input V / Current reference Input

INPUT OUTPUT CONNECTION CARD

In the following chart you can find a configuration exemple of Input and Output signals group, which are available on the connectors of the regulation card.

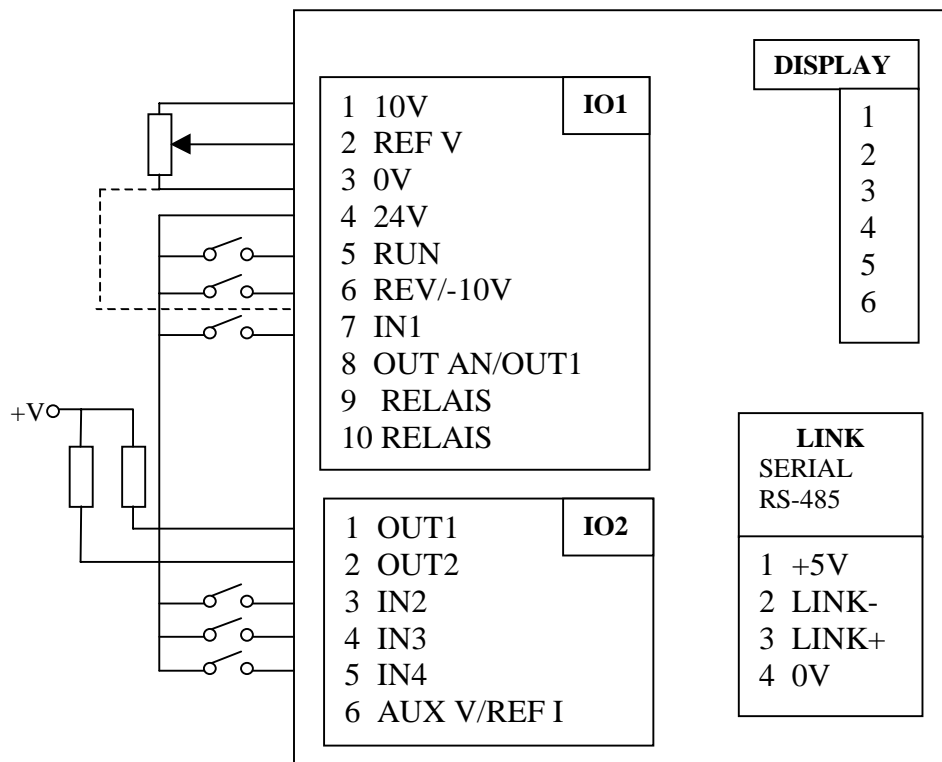

6. DIAGNOSTIC AND INTERVENTION



Almost all the operations of functioning and diagnosis check of the devices do not require to open the control box. If absolutely necessary to go inside the box, before opening the cover, disconnect all the system phase conductors and wait at least five minutes because the inner voltage reach the value for the operator s safety. In any situation, please check that:

- the conductors are disconnected and placed under the maintainer control .
- all mechanical masses, kinematically connected to the shaft drive are fixed and that sudden starts can t succeed for the dragging of the shaft drive from external mechanical organs.

In case of breakdown or non functioning, ESV signals by the display the code error. For several alarms is it possible the manual reset : push both the arrow key .

Code	Description of Causes and Remedies
C.Err	Error in configuring memory. It is activated starting ESV. In order to go out, please, put off ESV and after some minutes put it in.
P.Err	Error in parameters memory. It is activated only if parameters of the memory are congruent. Causes: accidental parameters loss (if ESV is put off during recording phase), memory fault. If there is an accidental loss : put off ESV and put it in after some minutes: parameters with function C-02 will be recorded.
OC	Overcurrent protection: it is activated when current goes over the maximum threshold in order to protect the electronic card; it indicates also phase short-circuiter and towards earth. Please, verify before putting ESV in again.
OU	Overtention Protection: it is activated when capacitors connectors tension goes over the maximum threshold in order to protect the electronic card. Verify the acceleration times or braking resistance integrity.
UU	Energised protection: it is activated when the tension of the filter capacitors connectors goes under the minimum threshold in order prevent ESV from wrong performances caused by torque limitation. Ab.31=0 forbid the alarm recording.
OH	Overtemperature protection: it is activated when heatsink temperature goes over the maximum threshold in order to protect the electronic card. Autoreset is not possible.
OLi	Card overloading Protection: it is activated when steady-state current goes over the maximum threshold for the maximum time limit (IxT). Autoreset is not possible.
OLM	Motor overloading protection: it is activated when steady-state current goes over the maximum threshold for the maximum time limit ($I^2 \times T$) in order to protect the motor. Levels and times depend on the setting up of motor specific data. Autoreset is not possible.
Olr	Protection against resistance braking overloading: it is activated when dissipated power goes over the maximum threshold for the maximum arranged time. . Levels and times depend on the setting up of motor specific resistance data. Autoreset is not possible.
Ot	Motor instant overload protection: it is activated only if recorded (Ab.18=1), when torque produced by the motor goes over the arranged threshold for the arranged time in order to protect the mechanical linked transmission drives and the material.
Ph	Protection against the lack of feeding phase: it is active 30 seconds after a disconnection of a feeding phase. Autoreset is not possible.



In case of non functioning or system block the motor s system is disconnected and the rotor is free to round; be careful this behaviour and the use modalities of the machine to which ESV is assembled cannot cause dangerous situations.

7. MANTEINANCE

7.1 Warnings



The user cannot maintain or repair ESV components. In case of damages or functioning problems contact the authorised service only.

7.2 Cleaning and ordinary maintenance

The only ordinary maintenance ESV requires is the periodical cleaning check of the cooling system. This operation must have a monthly frequency if the device works in normal environmental conditions and weekly or more frequently it works in particularly dusty rooms or which cause the deposit of substances that could reduce the cooling system efficacy.



During the maintenance and cleaning operation make sure the control box cover and the fairled of the supply cable are fixed in the right way, not to let dust and dirty enter the device, causing possible problems to the electronics.

For ordinary maintenance follow this **procedure**:

1. Disconnect all ESV phase conductors;
2. Check all the motor s side cooling fin, the fan back protection grid and the cooling fins in the back side of the control box are free from dust deposit, rubbish, dirty;
3. On the contrary clean them by using torns or compressed air with medium pressure. In extreme cases wash the device with a weak jet of water, letting then it dry;
4. Supply the system again;
5. Check the cooling is easy inside all the cooling fins, otherwise clean it again.

7.3 Periodical inspection

It is recommended to make it periodically, according on using conditions and however at least monthly:

- a. Maintenance of the free ventilation space (par. 4.3).
- b. Motor cleaning (par. 7.2).
- c. Quality of wiring connections (par. 4.5).
- d. Check of the right and solid connection of the motor to its mechanic load.
- e. ensure that vibrations don t damage the electronic components

If between the supply and the start up have passed more than 4 years but in good storing conditions (dry environment and free from dust and vibrations), or more than 2 years in bad conditions, it is due to replace the motor bearings.

The motor humidity must be taken away by using an external heating.

7.4 Replacing of bearings or other spare parts.

Contact STM, avoiding disassembling.

8. PLACING OUT OF SERVICE

In case ESV is not working any more and it is thrown away, please note that:

- There is an explosion danger of the electrolytic condensers inside the control box if the product is kept at high temperatures, (like in incinerators);
- The plastic material could release, if burned, venomous gases and very toxic;
- ESV is considered as a «special, non dangerous » product for UE laws. It is necessary to dispose it following the local norms and regulations.

9. Appendix

9.1 Motopotentiometer Menu

COD.	DESCRIPTION
Mt-0	Motor speed reference modification by means of arrow keys ↑ and ↓
Mt-1	Speed estimate modification for the conversion constant d-32*A.18
Mt-2	frequency reference modification

9.2 Display Menu

COD.	DESCRIPTION	RANGE	UNIT	DEF
d-00	Output Frequency		0.1Hz	
d-01	Reference Frequency	From fmin to fmax	0.1 Hz	
d-02	Output current (rms)		0.1 A	
d-03	Output voltage (rms)		1 V	
d-04	Continuous voltage (dc)		1 V	
d-05	Output frequency for the conversion coefficient (d-00*A.18)		0.01 / 1	
d-06	Reference speed for the conversion coefficient (d-01*A.18)		0.01 / 1	
d-07	Cos φ		0.01	
d-08	Mechanical power estimate		0.01Kw	
d-09	Overloading (100% = alarm threshold)		0.1%	
d-10	Motor overloading (100% = alarm threshold)		0.1%	
d-11	Braking Resistor overloading (100% alarm threshold)		0.1%	
d-12	Last alarm memory	The alarms can be reset by the command C-03		
d-13	Second to last alarm memory			
d-14	Third to last alarm memory			
d-15	Fourth to alarm memory			
d-16	Digital inputs state			
d-17	Digital Outputs state			
d-18	Not used			
d-19	Not used			
d-20	Not used			
d-21	Not used			

d-22	PID reference		0,1%	
d-23	PID feedback pid		0,1%	
d-24	PID error		0,1%	
d-25	PID integral component		0,1%	
d-26	PID output		0,1%	
d-27	Control nominal current			
d-28	Software version	xx.xx		
d-29	Identification code	Xxxx		
d-30	Display test	All segment turn on		
d-31	display MEC			
d-32	Synchronism Speed display [rpm] or calculated following Ab.55		[rpm]	
d-33	Speed display in rpm for the conversion:d-32*A.18		[rpm]	
d-34	Speed reference display.		[rpm]	
d-35	Thermal image display as configured by NTC sensor (alarm signal when it goes to A.92,es A.92=42 C about 70 C)			

Display of digital input and output with **d-16** and **d-17**

NOTE: Each segment, when lit, indicates that the corresponding I / O is active.

- Inputs:

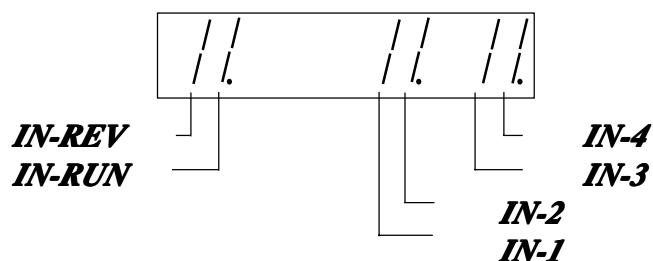

- Outputs:

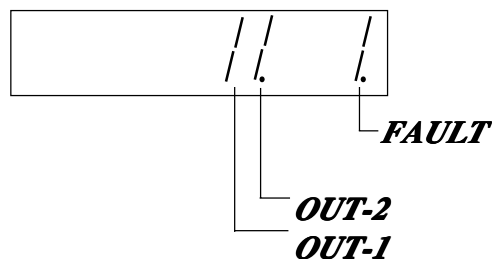

9.3 F MENU: sets and/or reads the frequencies that can be selected by remotation cable IO1 or IO1+IO2

CODE	DESCRIPTION	RANGE	UNIT	PRESET VALUE	PAGE
F-00	Reference frequency 0	0,0 / 480,0	0,1 Hz	0,0	35
F-01	Reference frequency 1	" "	" "	" "	"
F-02	Reference frequency 2	" "	" "	" "	"
F-03	Reference frequency 3	" "	" "	" "	"
F-04	Reference frequency 4	" "	" "	" "	"
F-05	Reference frequency 5	" "	" "	" "	"
F-06	Reference frequency 6	" "	" "	" "	"
F-07	Reference frequency 7	" "	" "	" "	"
F-08	Jogging frequency	" "	" "	10.0	32

In order to use frequency menu sets the parameter A00=3, use the digital inputs IN1,IN2,IN3,IN4 and program like showed at pag 33.

9.4 C MENU: sets and executes some controls: to execute them, select value 7 and confirm through E.

CODE	ACTION PERFORMED	
C-00	Permanent storage of all parameters	(*)
C-01	Recall of previously stored parameters (the currently used parameters are replaced by the previously stored ones)	(*)
C-02	Recall of factory-preset parameters (the storage depends on the operator's choice)	(*)
C-03	Zero setting of alarms memory	
C-04	Recall and storage of the parameter s contained in the external programming key	(*)
C-05	Storage of the esv parameters on external programming key	
C-06	Measure of motor phase resistance and corresponding initialization of parameter A. 14 (page33)	(*)

NOTE: The sign (*) means the controls cannot be executed with running motor.

Code	Description	Range	Unit	Preset value	Page
A.00	reference setting	0 - 5	1	5	28
A.01	maximum frequency	50,0 - 480,0	0,1 Hz	50,0 (*)	"
A.02	min. frequency (offset) for frequency analog reference	-480/+480	1 HZ	4 (*)	"
A.03	acceleration time 1	0,01 - 9999	0,01 / 0,1 / 1 s	5,0 (*)	"
A.04	deceleration time 1	0,01 - 9999	0,01 / 0,1 / 1 s	5,0	"
A.05	parameter protection	0 - 2	1	1	22
A.06	delay of run after opening mechanical brake	0-1250	1ms	100ms	
A.07	V/F characteristic type	0-4	1	1	29
A.08	torque boost at low revolutions (manual boost)	0-30	1% di (A.16)	3 (*)	"
A.09	"S"-curve characteristic	0,0-10,0	0,1s	0,0	30
A.10	modulation frequency	0-5	1	3	"
A.11	motor rated current	(20%-150%) Inom	0,1 A	Inom	
A.12	motor thermal constant	1 - 120	1 min.	20	
A.13	rating of motor $\cos \varphi$	0,01 - 1,00	0,01	(**)	
A.14	motor stator resistance	0,0 - 25,0	0,1 ohm	0,0	31
A.15	motor efficiency	0 - 100%	1	100	
A.16	max. output voltage	(A.63) (**)	1 Hz	(**)	29
A.17	gain for frequency analog reference	0,00 - 9,99	0,01	1,00	
A.18	conversion constant (***)	0,01 - 99,99	0,01	1,00	
A.19	display message setting at startup (d-xx value)	0 - 35	1	0	
A.20	poles motor	2 - 10	1	4	
A.21	acceleration time 2	0,01 - 9999	0,01 / 0,1 / 1 s	32	
A.22	deceleration time 2	0,01 - 9999	0,01 / 0,1 / 1 s	10,0	
A.23	resolution for accel./decel. ramps	0=0,01s 1=0,1s 2=1s	0,01 / 0,1 / 1 s	10,0	30
A.24	DC braking level	0-100	0,01 / 0,1 / 1 s	1	36
A.25	frequency for DC braking enabling	0,0 - 480	0,01 / 0,1 / 1 s	0	"
A.26	DC braking time at start	0,0-60	0,01 / 0,1 / 1 s	0	"
A.27	DC braking time at stop	0,0-60	1	0,0	"
A.28	slip compensation	0,0 - 25	1% of Inom	(**)	32
A.29	time constant of slip compensation	0 - 10	0,1 Hz	0,1	"
A.30	jump frequency 1	0,0 / 480,0	0,1 s	0,0	30
A.31	jump frequency 2	0,0 / 480,0	0,1 s	0,0	"
A.32	jump amplitude	0 - 100	0,1 %	0,0	"
A.33	output frequency upper limit	(A.34) - 110	0,1 s	100	"
A.34	output frequency lower limit	0 - (A.33)	0,1 Hz	0	"
A.35	IN1 input configuration	0 - 15	0,1 Hz	1	30/33
A.36	IN2 input configuration	0 - 15	0,1 Hz	2	"
A.37	IN3 input configuration	0 - 15	1% of (P-01)	3	"
A.38	IN4 input configuration	0 - 15	1% of (P-01)	4	"
A.39	OUT1 output configuration	0 - 15	1	0 (*)	35
A.40	OUT2 output configuration	0 - 35	1	5 (*)	"
A.41	auxiliary analog input configuration AUX-V	0 - 11	1	0 (*)	34
A.42	analog output configuration OUT-AN	0 - 10	1	0	"
A.43	analog output offset OUT-AN	-9,99 - 9,99	0,01V	0 (*)	
A.44	analog output gain OUT-AN	-9,99 / +9,99	0,01V	1,00	35

NOTE: (**) : the parameter values depend on the ESV size;
 (*) : the controls can be executed with stopped motor only;
 (***) : A.18 allows to convert the frequency displayed in d-00 as output speed .

ESV PARAMETERS

Code	Description	Range	Unit	Preset value	Page
A.45	analog output time constant	0,00 - 2,50	0,01	0,0 (*)	35
A.46	max. amplitude of offset frequency from AUX-V	0 - 100	1%ofA.01	0	"
A.47	signalling frequency	0,0 - 480,0	0,1Hz	0,0 (*)	34
A.48	hysteresis amplitude related to A.47	0,0 - 100,0	0,1Hz	0,0 (*)	
A.49	current limit for overload	20 - 200	1%(mot.)	110	
A.50	delay time for overload signaling	0,1 - 25,0	0,1s	0,1	32
A.51	autoreset time	0,1 - 60,0	0,1 s	5,0	"
A.52	number of autoreset attempts	0 - 250	1	1	38
A.53	ohmic value of braking resistor	0 - 250	1 ohm	(**)	"
A.54	braking resistor power	10 - 2500	10 W	(**)	36
A.55	braking resistor thermic constant	5 - 1250	5 s	(**)	"
A.56	inputs setting by serial line enabling	0 - 255	1	0	"
A.57	outputs setting by serial line enabling	0 - 15	1	0	39
A.58	serial line configuration	0-19	1	1	"
A.59	serial line address	0 - 99	1	0	"
A.60	answer delay time on serial line	0 - 250	1 ms	1	"
A.61	base frequency	(A.62) - 480,0	0,1 Hz	50	"
A.62	V / F intermediate frequency	0 - (A.61)	0,1 Hz	25	29
A.63	V / F intermediate voltage	0 - (A.16)	1V	(**)	"
A.64	ramp start/stop frequency	0 - 25,0	0,1 Hz	0,0	"
A.65	output voltage reduction	0 - 100	1%of A.16	100	"
A.66	undervoltage threshold	40 - 80	1%of A.16	70	"
A.67	max. time of short mains blackout	0,1 - 25,0	0,1 s	1,0	32
A.68	current limit in accel. for $f < f_{base}$	20 - 200	1%(Inom)	170	"
A.69	current limit in accel. for $f > f_{base}$	20 - 200	1%(Inom)	170	31
A.70	current limit at constant speed	20 - 200	1%(Inom)	170	"
A.71	current limit for motor pickup	20 - 200	1%(Inom)	120 (*)	"
A.72	demagnetization time	0,01-10	0,01 s	(**) (*)	32
A.73	deceleration speed to prevent stall at constant speed	0,1 -25	0,1 s	1,0 (*)	"
A.74	frequency scan time during motor pickup	0,1-25	0,1s	1,0 (*)	"
A.75	voltage reset time	0,1-25	0,1s	0,2	"
A.76	tolerance at constant speed	0,1-25	0,1 Hz	0,5 (*)	"
A.77	ramp end delay / constant speed	0,1-25	0,1s	1,0 (*)	31
A.80	time out receiving	0,0-25s	0,1s	0,0	
A.81	PID reference	0,0-100	0,1%	0,0	37
A.82	PID max. positive error	0,1 - 100	0,1%	5,0	"
A.83	PID max. negative error	0,1 - 100	0,1%	5,0	"
A.84	PID updating time	0,00(=0,005) - 2,5	0,01 s	0,00	"
A.85	proportional term gain	0,00 - 99,99	0,01	0,00	"
A.86	integral action time set 1	0,00 - 99,99	0,01	99,99	"
A.87	derivative action time	0,00 - 99,99	0,01	0,00	"
A.88	proportional term gain	0,00 - 99,99	0,01	0,00	"
A.89	integral action time set 2	0,00 - 99,99	0,01	99,99	"
A.90	derivative action time	0,00 - 99,99	0,01	0,00	"
A.91	active start motopotentiometer	0-2	1	0	21
A.92	thermal alarm level NTC	10,0-102,0	1°C	100,0	
A.93	acceleration time 4	0,01-9999	0,01 / 0,1 / 1 s	1,0	
A.94	deceleration time 4	0,01-9999	0,01 / 0,1 / 1 s	1,0	

NOTE: (**) the parameter values depend on the inverter size; (*) the controls can be executed

Code	Description	Range		Preset value	Page
Ab-00	run/reverse inputs configuration	0=RUN/REV	1=FWD/REV	0	30
Ab-01	direction rotation	0=CW	1=CCW	0	
Ab-02	protection	0=off	1=on	1	33
Ab-03	stop mode	0=in ramp	1=coast	1	"
Ab-04	motopotentiometer memory when switch of ESV	0=off	1=on	0	
Ab-05	reversal enabling	0=off	1=on	1	33
Ab-06	external alarm tripping mode	0=alarm/lock	1=control disabled	0	"
Ab-07	external alarm detection mode	0=always	1=run only	0	"
Ab-08	current input	0 = 0/20mA	1=4 / 20 mAv	0	
Ab-09	enabling of motor overload protection	0=off	1=on	0	31
Ab-10	motor type	0=standard	1=servo-ventilated	0	
Ab-11	configuration of external alarm input	1=NO(nor.open)	1=NC(nor. closed)	0	33
Ab-12	reference inputs reversal	0=alarm/lock	1=inverter disabl.	0	
Ab-13	autoreset handling in case of external alarm	0=off	1=on	0	33
Ab-14	autoreset enabling	0=off	1=on	0	38
Ab-15	enabling of autoreset attempts limitation	0=off	1=on	1	"
Ab-16	enabling of autoreset of auto zero-setting attempts	0=off	1=on (10 min.)	0	"
Ab-17	alarm contact during autoreset	0=off	1=on	1	"
Ab-18	voltage reduction tripping mode	0=off	1=const. speed only	0	29
Ab-19	enabling of momentary overload control	0=always	1=on	0	32
Ab-20	tripping mode of momentary overload control	0=off	1=const. speed only	0	"
Ab-21	enabling of momentary overload alarm	0=off	1=on	0	"
Ab-22	enabling of braking resistor overload protection	0=off	1=on	0	36
Ab-23	stall prevention during acceleration	0=off	1=on	1	31
Ab-24	stall prevention at constant speed	0=off	1=on	1	"
Ab-25	stall prevention during deceleration	0=off	1=on	1	"
Ab-26	overvoltage prevention	0=off	1=on	0	"

ESV PARAMETERS

AbMENU:

Code	Description	Range		Preset value	Page
Ab-27	prevention of short mains blackout	0=off	1=on	0	32
Ab-28	motor pickup enabling (flying restart)	0=off	1=on	0	"
Ab-29	scan start frequency for pickup control	0=reference freq.	1=max. frequency	0	"
Ab-30	motor pickup at startup	0=off	1=on	0	"
Ab-31	automatic adjustment of output voltage	0=off	1=on	1	
Ab-32	dead times compensation	0=off	1=on	1	30
Ab-33	automatic boost enabling	0=off	1=on	1	32
Ab-34	enabling of switching frequency reduction under 5 Hz	0=off	1=on	0	30
Ab-35	enabling of undervoltage alarm storage	0=off	1=on	1	
Ab-36	overmodulation	0=off	1=on	0	
Ab-37	keyboard controls enabling	0=normal	1=weak	1	
Ab-38	PID regulator enabling	0=off	1=on	0	37
Ab-39	regulator tripping mode	0=off	1=on	0	"
Ab-40	enabling of encoder / PID synchronism	0=running	1=const. speed run	0	"
Ab-41	variable adjusted by PID regulator	0=off	1=on	0	"
Ab-42	error sign reversal	0=frequency	1=voltage	0	"
Ab-43	adjustment mode	0=off	1=on	0	"
Ab-44	suppression of PID regulator positive output	0=direct	1=sum(feed/forw.)	0	"
Ab-45	suppression of PID regulator negative output	0=off	1=on	0	"
Ab-46	suppression of positive or negative integral term	0=off	1=on	0	"
Ab-47	integral term initialization at start	0=off	1=on	0	"
Ab-48	} PID reference input switches	see following table		0	"
Ab-49				0	"
Ab-50				0	"
Ab-51	} PID feedback input switches	see following table		1	"
Ab-52				0	"
Ab-53				0	"
Ab-54	display at start	0=[d-xx]	1=[Mt-x]	1	
Ab-55	rpm displayed with d.32	0=synchronism	1=speed estimate	1	
Ab-56	driving rele precharge	0=normal	1=software	1	
Ab-57	enabling slip compensation	0=off	1=on	1	

	feedback switches				reference switches		
	Ab53	Ab52	Ab51		Ab50	Ab49	Ab48
	-	-	-	reference frequency	0	0	0
not used	0	0	1	not used	0	0	1
AUX-V	0	1	0	AUX-V	0	1	0
REF-V	0	1	1	REF-V	0	1	1
REF-I	1	0	0	REF-I	1	0	0
	-	-	-	parameter A.81	1	0	1
	-	-	-	freq. after ramp	1	1	0
current	1	0	1	generator	-	-	-
torque	1	1	0		-	-	-
power	1	1	1		-	-	-
set to 0	0	0	0	set to 0	1	1	1

9.8 Frequency reference setting

PARAMETER	FUNCTION	RANGE [DEFAULT]	VALUES	DESCRIPTION	ASSOCIATED PARAMETERS
A.00	Determines the ESV operation frequency	0 - 5 [5]	0 1 2 3 4 5	Each parameter value correspond to a different reference:	A.01, A.02 A.17, Ab.12
				0 analog input: REF-V (0/10V)	
				1 analog input: REF-V (-/+10V) - the polarity determines the rotation direction	
				2 analog input: REF-I (0/20mA: [b-05=0] or 4/20mA: [b-05=1])	
				3 selects the frequency set by parameter F-00	
				4 input from serial line with 0,01 Hz resolution	
5 motopotentiometer reference					
A.01	Indicates the max. operation frequency (Hz)	50,0 - 480,0 [50,0]		The value set for A.01 indicates the max. operation frequency and also the full scale value for the analog inputs or the parallel digital inputs	

When selecting the analog input, it is possible to change the formula that transforms the reference input signal into the motor supply frequency through the following parameters:

- A.02** determines the minimum frequency (offset); it can assume negative values too.
- A.17** determines the gain.
- Ab.12** enables the formula reversal (a minimum signal corresponds to a maximum frequency).

Let us assume that the input is a 0/10 Vvoltage analog signal:

Direct formula: **Ab.12=0**

Inverse formula: **Ab.12=1**

$$Frif. = ((A.01 - A.02) * \frac{\text{volt}}{10} * A.17) + A.02$$

$$Frif. = A.01 - (((A.01 - A.02) * \frac{\text{volt}}{10} * A.17) + A.02)$$

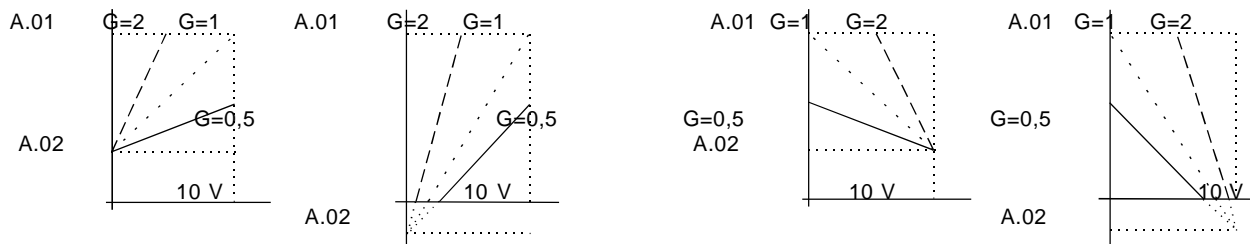

In any case Fref. will always be limited between **A.64** and **A.01**.

As a alternative to the above mentioned method, the frequency reference can be selected by re-calling some frequencies preset through parameters **F**, by means of some contacts to be connected to 3 of the 4 digital input. To do so, you must configure as a reference frequency switches, 3 of the 4 inputs with parameters, according to the following order :**A.35**, **A.36**, **A.37**, **A.38**. These inputs state will give the result indicated on the following table:

VALUES	INPUTS			DESCRIPTION
	Ix-F3	Ix-F2	Ix-F1	
	off	off	off	the main reference selected through parameter A.00 is active
	off	off	on	frequency F-01 (or the reference from AUX-V if A.53=1) is active
	off	on	off	frequency F-02 is active
	off	on	on	frequency F-03 is active
	on	off	off	frequency F-04 is active
	on	off	on	frequency F-05 is active
	on	on	off	frequency F-06 is active
	on	on	on	frequency F-07 is active

NOTE: The " on " state indicates a closed contact; the selection switches not used are considered as " off ".

- The AUX-V input allows adding or subtracting a frequency, proportional to the 0/10V signal applied .

9.9 Setting of motor voltage/frequency characteristic

PARAMETER	FUNCTION	RANGE [DEFAULT]	VALUES	DESCRIPTION	ASSOCIATED PARAMETERS
A.07	Determines the voltage to be applied to the motor as a function of the frequency	0 - 4 [1]		Each parameter value correspond to a different characteristic:	
			0	user-defined characteristic	A.16,A.08,A.61,A.62,A.63,A.64,A.65,A.75,Ab.18,Ab.31
			1	linear characteristic for 50 Hz motors	A.16,A.08,A.64,A.65 Ab.18 Ab31
			2	linear characteristic for 60 Hz motors	
			3	quadratic characteristic for 50 Hz motors	
4	quadratic characteristic for 60 Hz motors				

PARAMETER	FUNCTION	RANGE [DEFAULT]	DESCRIPTION
A.61	To customize the characteristic:	(A.62) - 480,0 [50,0] (Hz)	Selects the motor base frequency (rated); this frequency is associated to the motor max. voltage set through A.16 .
A.62	the change is possible only if A.07 = 0	0 - (A.61) [25,0] (Hz)	Selects the intermediate frequency.
A.63		0 - (A.16) [(**)] (V)	Selects the voltage applied to the motor as regards the intermediate frequency.
A.16	Selects the max. voltage applied to the motor.	(A.63) - (**) [(**)] (V)	To make this value independent from the ESV supply voltage fluctuation enable the automatic adjustment function of the output voltage by setting Ab.31=1 . In this case, the ESV can be supplied through a voltage higher than the motor rated one. If Ab.31=0 then the voltage value setted by A.16 must matches the motor rated voltage.
A.08	Increases the output voltage at 0 Hz (calculated in % of A.16) and also the torque .	0 - 30 [3]	The value of the applied voltage can be controlled through the terminal board by applying a 0/10 V signal to the AUX-V input and setting A.41=10 . This voltage is added to the V/F characteristic in a decreasing way, until it is annulled at the intermediate frequency (A.62). (fig. A)
A.64	Selects the frequency applied to the motor at start.	0 - 25,0 [0,0] (Hz)	Is the ramp begin frequency at start and the ramp end frequency at stop.
A.65	Limits the voltage value applied to the motor (in % of A.16).	0 - 100 [100]	The maximum output voltage value is limited to $(A.65 \cdot A.16) / 100$ value. This value can be adjusted through terminal board by applying a 0/10 V signal to the AUX-V input and setting A.41=2
Ab.18	Controls the voltage reduction set through parameter A.65.	0=always; 1=const.speed only [0]	If Ab.18=0 , the reduction is always active; if Ab.18=1 the reduction is inactive during the ramps, so that the torque is completely available both in acceleration and deceleration state. (fig. B)
A.75	Determines the max. speed of voltage change.	0,1 - 25,0 (s) [0,2]	Time to go to from 0% to 100% of V and viceversa NOTE : too short times cause excessive current peaks.

[(**)] = The default values of the parameters depends on the ESV size.

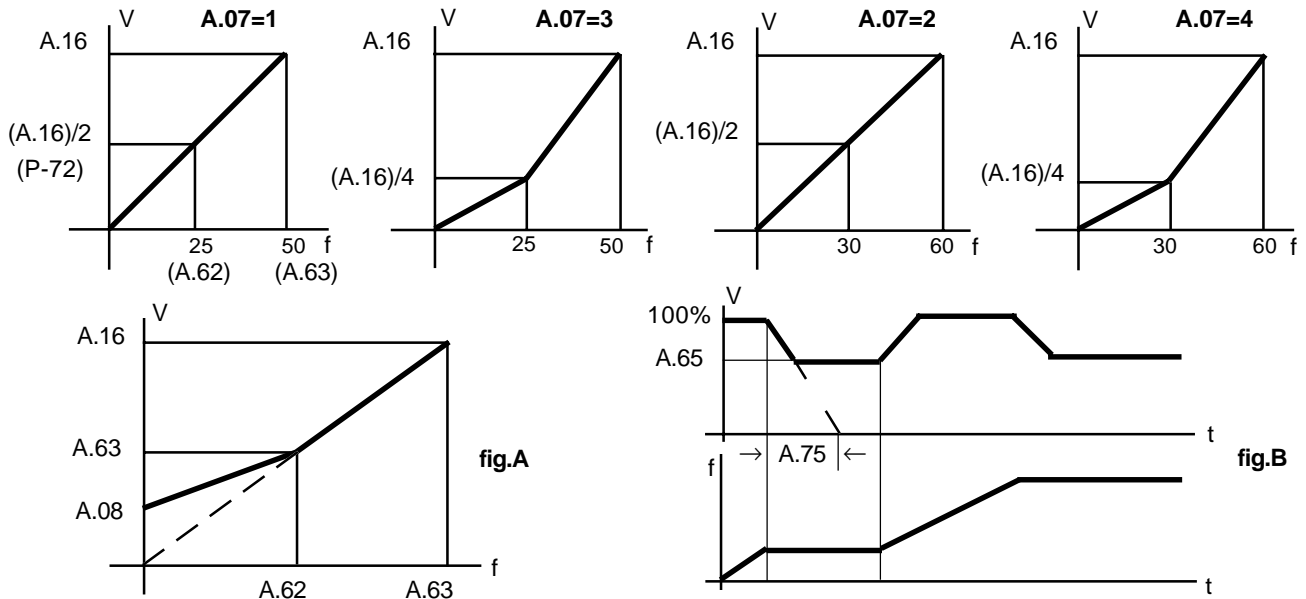

9.10 Frequency jumps -Output frequency limitations -Jogging -Switching frequency -Accel. and decel.ramps

PARAMETER	FUNCTION	RANGE [DEFAULT]	DESCRIPTION									
A.30	Jump frequency no. 1	0,0 - 480,0 [0,0] (Hz)	Particular frequencies with which the inverter supplies the motor can cause undesired vibrations to the mechanical parts coupled to the motor. Parameters A.30 and A.31 can be set to exclude two of these frequency. Defines the frequency interval amplitude, to the left or right of the jump frequency. E.g.: the interval around jump frequency no. 1 ranges from (A.30)-(A.31) to (A.30)+(A.31) . Note: the two intervals can overlap. To disable an interval, the related frequency set by A.30 or A.31 must be set to 0 Hz.									
A.31	Jump frequency no. 2	0,0 - 480,0 [0,0] (Hz)										
A.32	The frequency interval Δf to the left or right of the jump frequency	0,0 - 100,0 [0,0] (Hz)										
A.33	Upper limit of the output frequency (% di P-01)	(A.34) - 110 [100]	The output frequency can be limited independently of the maximum and minimum values defined by parameters A.01 e A.02 . The output frequency can exceed the maximum frequency set by A.01 up to the max. value of 110%. This is done by using the slip compensation function or the speed feedback with the PID regulator.									
A.34	Lower limit of the output frequency (% di P-01)	0 - (A.33) [0]										
Ab.00	Selects the sequence followed by the RUN and REV together with the input Ix-JOG	0 = off - 1 = on [0]	JOGGING is a particular run control to advance the motor by small amounts. It applies preset frequencies to the motor through parameter F-08 . It does not allow DC current braking at startup or in stop condition. If Ab.00 = 0 : RUN = run, REV = reversal, and the input Ix-JOG handles the jogging control. If RUN and Ix-JOG are simultaneously enabled the first one enabled will override the other one. If Ab.00 = 1 : RUN = forward run, REV = backward run, the Ix-JOG enables the jogging control that overrides the normal run control.									
A.10	Selects switching frequency (executable with stopped motor only)	0 - 7 [5]	0 = 1kHz; 1 = 2 kHz; 2 = 3 kHz; 3 = 6 kHz; 4 = 9 kHz; 5 = 12 kHz. High values of the switching frequency reduce or eliminate the electric "noise" generated by the motor; viceversa, low values give a higher rotation fluidity at low speed, especially if high torques are required.									
Ab.32	Dead time compensation	0 = off - 1 = on [1]	Dead times compensation: it improves the torque and fluidity actions at low speed.									
Ab.34	They optimise the performance if high switching frequency are used	0 = off - 1 = on [0]	In case of output frequencies below 5 Hz, a 3 kHz switching frequency is automatically selected.									
A.35 A.36 A.37 A.38	Configure 2 out of control block inputs as ramp selectors	5 / 6	5 enables Ix-T1 as ramp selector - 6 enables Ix-T2 as ramp selectors The Ix-T1 and Ix-T2 inputs state, given by the contacts connected to the terminal board, will give the result shown on the following table: <table border="1" style="margin: 10px auto;"> <thead> <tr> <th>Ix-T2</th> <th>Ix-T1</th> <th>DESCRIPTION</th> </tr> </thead> <tbody> <tr> <td>off</td> <td>off</td> <td>accel./decel. ramp 1 (A.03 = accel. time - A.04 = decel. time)</td> </tr> <tr> <td>off</td> <td>on</td> <td>accel./decel. ramp 2 (A.21 = accel. time - A.22 = decel. time)</td> </tr> </tbody> </table> <p>Note: a) on = closed contact; the controls not used are considered in off state. b) When the jogging control Ix-JOG is active, the acceleration and deceleration times are fixed c) The modification of A.23 can affect the values entered on A.01, A.16, A.21, A.22 so these values must be rechecked. d) If a variable signal between 0V and 10V is connected to the AUX-V input the accel./decel. ramps can be extended proportionally to this signal value, under control of A.41; (e.g.: 2(s) x 8(V)= 16 s ramp extension). e) The ramp extension can also be generated if the functions of motor stall and ESV lock are enabled. This actuation is signaled by a flashing GREEN LED and also on terminal board by properly programming OUT1/2.</p>	Ix-T2	Ix-T1	DESCRIPTION	off	off	accel./decel. ramp 1 (A.03 = accel. time - A.04 = decel. time)	off	on	accel./decel. ramp 2 (A.21 = accel. time - A.22 = decel. time)
Ix-T2	Ix-T1	DESCRIPTION										
off	off	accel./decel. ramp 1 (A.03 = accel. time - A.04 = decel. time)										
off	on	accel./decel. ramp 2 (A.21 = accel. time - A.22 = decel. time)										
A.09	Select the ramp form	0,0 = linear ramp form; 0,1s - 10,0 s = "S" shaped ramp form										
A.23	Selects the resolution trough wich the ramp times are defined	0 = 0,01s to 99,99 s 1 = 0,1s to 999,9 s 2 = 1s to 9999 s [1]										
			Linear ramps and " S " shaped ramps									

9.11 Motor data setting - Motor thermal protection - Prevention of motor stall - inverter lock			
PARAMETER	FUNCTION	RANGE [DEFAULT]	DESCRIPTION
A.11	Motor rated current (from the rating)	(20-150)% Inom. [Inom] (A)	<p>To take advantage of the ESV/motor system features, it is necessary to set the characteristics of the motor used, through the parameters.</p> <p>A.12 can be calculated, (necessary only if the motor thermal protection function is enabled, par. Ab.09). The higher the value set, the higher the motor capacity of supporting currents higher than the rated one.</p> <p>The value of A.14 represents the motor phase resistance in case of star connection, or 1/3 of the phase resistance in case of delta connection. To get the proper value of A.14, use the function C-06:</p> <ul style="list-style-type: none"> - 1) Use M to select the C menu DISPLAY: C-00 - 2) Use the ↑, ↓ keys to select the code 06 DISPLAY: C-06 and press E: the display will show the value of C-06 DISPLAY: 0 - 3) Use the ↑, ↓ keys to select the code 07 DISPLAY: 7 and press E: the stator resistance is automatically measured . <p>The display will confirm that the operation has been executed .(To see the measured value, read the value of A.14 that, if necessary, can be manually modified).</p>
A.12	Sets the motor thermic constant	1 - (120) [20] (min)	
A.13	Motor cos φ (obtained from the rating)	0,01 - 1,00 [(**)]	
A.14	Equivalent stator resistance	0,0 - 25,0 [0,0] (ohm)	
Ab.09	Enable the thermal protection of the motor	0 = off - 1 = on [1]	<p>0 = standard motor, not servo-ventilated, at low revolution number not able to support the rated current (derating), the continuous current of DC braking is reduced by 50% (the motor is able to support a continuous current that is 50% of the rated one).</p> <p>1 = servo-ventilated motor;specify the type of motor used through parameter Ab.10.The level reached by the protection can be read in d-10, measured in % of the max. thermic overload allowed for the motor. When this level reaches 100%. the protection trips and the inverter is locked.</p>
Ab.23	Limits the acceleration current.	0 = off - 1 = on [1]	<p>Excessive current or voltage can cause motor stall or ESV lock conditions due to protections tripping.The aim of the parameter is to set thresholds that, when exceeded, trip some actions that limit currents and voltages:</p> <p>Ab.24: if the threshold programmed through A.68 (in acceleration state and if $f < A.61$, constant torque zone), or through A.69 ((in acceleration state and if $f > A.61$, constant power zone) is exceeded, the ramp is stopped until the current remains over this threshold.</p> <p>Ab.24: if the threshold programmed through A.70 is exceeded (constant speed operation) the output frequency is reduced at a rate controlled by A.73; As soon as f falls below the threshold the frequency start to increase with the selected ramp.</p> <p>Ab.25: the ramp is stopped when the voltage on filter capacitors is near the overvoltage threshold; when the V falls under the threshold the ramp start again; NOTE: the function can be unable to prevent the inverter lock in case of high-inertia loads and short ramps.</p> <p>Ab.26: if the voltage on filter capacitors exceeds the overvoltage threshold, the output voltage is set to zero (corresponding to a coast-to-stop). As soon as the voltage reaches safety levels,a free rotation motor pickup is executed and the deceleration ramp is restarted.</p> <p>NOTE: too short ramps can lock the inverter by overvoltage.</p> <p>The parameters allows to distinguish between the acceleration or deceleration state and the constant speed state . In fact, acceleration ramps too short as regards the motor capacity, or slight reference variations, either intentional or not, does not mean the motor to be considered in constant acceleration or deceleration.</p> <p>A.76 set the indifference range to reference change as regards the constant speed; A.77, instead, set the time after which, starting from ramp completion, the motor is considered to be in constant speed state.</p>
Ab.24	Limits the current at constant speed.	0 = off - 1 = on [1]	
Ab.25	Limits the voltage during deceleration .	0 = off - 1 = on [1]	
Ab.26	Prevents overvoltage.	0 = off - 1 = on [0]	
A.68	The parameters set the current threshold as a % of Inom	20 - 200	
A.69		[170]	
A.70			
A.73	Set the deceleration ramp when Ab.24 is active	0,1 - 25 [1] (s)	
A.76	Set max. reference frequency after which start the ramp state.	0,1 - 25 [0,5] (Hz)	
A.77	Set the delay after which the motor is considered in constant speed state.	0,1 - 25 [1] (s)	

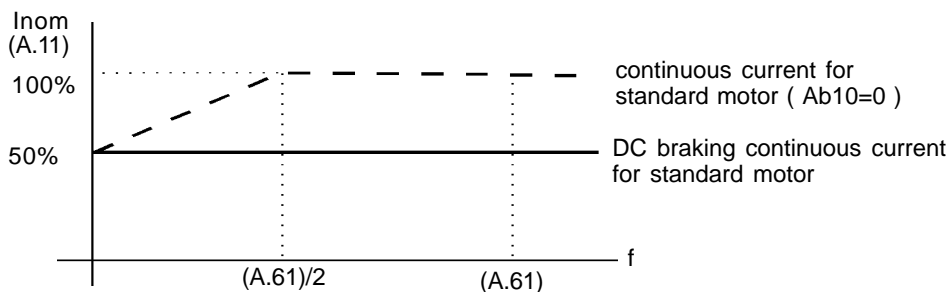

9.12 Slip compensation - Instantaneous overload signalling - Prevention of short mains blackout - Pickup of motor in free rotation (flying restart) - Automatic boost				
PARAMETER	FUNCTION	RANGE [DEFAULT]	DESCRIPTION	
A.28	Defines value of the motor rated slip (expressed in %)	0,0 - 25,0 [0,0]	The parameters compensate for the motor speed reduction when increasing the applied load (slip), changing the inverter output frequency proportionally to the applied load. Note: a too quick response (A.29 too short) can cause fluctuations in the output frequency. To obtain a good compensation properly set A.11 , A.13 , A.14 and if the reference frequency is close to the maximum frequency, it is advisable to set on A.33 a value beyond 100%	
A.29	Compensation time constant	0,0 - 10,0 [0,1] (s)		
Ab.19	Enable the overload detection function	0 = off - 1 = on [0]	The aim of the function which detects the overload is to signal or avoid excessive efforts on the load, causing the instantaneous locking of the inverter and the alarm signalling. The threshold defined by A.49 is in % of the motor rated load as obtained through parameters A.11 , A.13 . The threshold exceeding can be signalled through terminal board by configuring the Ox-GTT output. The parameter A.14 must be accurately set too. A.50 Set how long the overload can exceed the tripping threshold before the signalling and the ESV lock functions are enabled	
Ab.20	Select when the detection function is active	0=always - 1= at constant speed [0]		
Ab.21	Set the overload locked state	0 = off - 1 = on [0]		
A.49	Set the tripping level of the protection	20 - 200 [110] (%)		
A.50	Set the delay before the protection trip	0,1 - 25,0 [0,1] (s)		
Ab.27	Enables the prevention of short mains blackout	0 = off - 1 = on [0]	The parameters avoid locking the ESV when happen a short mains blackout. The mains cut off is signaled on the display and on the terminal board by configuring one of digital outputs OUT1 , OUT2 . Note: 1) on single phase ESV it is advisable to reduce the A.67 value to the minimum to prevent excessive startup currents. Otherwise it is possible that the ESV lock by undervoltage. The alarm is always enabled if the voltage falls under a given value that depends on the ESV size; 2) the tripping of the prevention function sets the output voltage to zero, (coast-to-stop). In this way, the filter capacitors are not completely discharged thus keeping the control logic active. As soon as the voltage exceeds the threshold (hysteresis of 6%), a pickup phase of motor in free rotation is performed, thus resetting the speed in force before the tripping.	
A.66	Determines the undervoltage protection tripping threshold	40 - 80 (% of A.16) [70]		
A.67	Set the max. duration of the short mains blackout before the undervoltage alarm is enabled	0,1 - 25,0 [1] (s)		
Ab.28	Enables the tripping of the motor pickup	0 = off - 1 = on [0]	The aim of the pickup function of motor in free rotation is to avoid the higher than normal startup currents generated when, for some causes the inverter cuts the voltage to the motor, then a subsequent run command makes a start from zero Hz with the motor still rotating. This function generates an initial frequency, Ab.29 , equal to or higher than the motor one, by gradually increasing, A.75 , the output voltage to 100 % and controlling that the current does not exceed a preset threshold set by A.71 , (it is advisable that this value should be lightly higher than the current absorbed by the motor) otherwise the output frequency would be reduced and the voltage would be limited. The delay between the cut off of the motor voltage and when the motor pickup phase start can be controlled by A.72 (demagnetization time). The motor is considered frequency-locked when a given frequency is reached so that, at full voltage, the current is under the threshold. The motor can then be accelerated or decelerated until the reference is reached. The motor pickup function can be enabled through terminal board by configuring one of the inputs as Ix-FLY input. If the Ix-FLY input is active, every time the run control is pressed the motor pickup is performed.	
Ab.29	Selects the initial scanning frequency	0=reference freq. 1=max. frequency [0]		
Ab.30	Enables the function with the first run control after startup	0 = off - 1 = on [0]		
A.71	Sets the max. current threshold during the motor pickup phase	20 - 200 (% of Inom) [120]		
A.72	Delay to activate the motor pickup function	0,01 - 10,00 [**] (s)		
A.74	Sets the rate of change of the frequency during the lock search	0,1 - 25,0 [1] (s)		
A.75	Set the max. rate of change of the voltage	0,1 - 25,0 [0,2] (s)		
	Enables the uses of an encoder for the motor pickup function	0 = off - 1 = on [0]		
Ab.33	Enables the automatic boost	0 = off - 1 = on [0]		This function is an alternative to the voltage (and torque) boost obtained through parameter A.08 . The output voltage is automatically increased as regards the motor and the connected load characteristics. The efficiency of the action depends on the accuracy applied when setting the parameters A.11 , A.13 , A.14 .

9.13 Programmable control inputs

NAME	FUNCTION		DESCRIPTION
REV	If Ab.00=0	Run reversal	The four digital input can be configured through parameter A.35,A.36,A.37,A.38 . Note: if the forward and backward run controls are simultaneously executed (Ab.00=1) a stop control effect is generated: the rotation reversal is obtained by decelerating, with selected ramp, up to a zero frequency, then accelerating up to the preset reference frequency.
RUN		Run	
EXTFLT		Alarm coming from outside	
IN1		Digital inputs that can be configured	
IN2			
IN3			
IN4			
		If Ab00=1	Backward run Forward run

Configuration parameters **A.35,A.36,A.37,A.38**.

PARAMETER VALUE	NAME	ACTION PERFORMED	
0	Ix-RES	Resets the alarms	NOTE: If no input is configured to enable (disable) a control, this control is automatically considered as active (inactive) as shown on the column DEFAULT STATE. The x symbol on the Name column must be substituted by the number of the input used.
1	Ix-F1	Reference frequency (as set by F-xx) selectors	
2	Ix-F2		
3	Ix-F3		
4	Ix-JOG		
5	Ix-T1	Acceleration/deceleration ramps selectors	
6	Ix-T2		
7	Ix-DE	Motor output enabling (if disabled, causes a coast-to-stop)	
8	Ix-DD	Motor output disabling (if enabled, causes a coast-to-stop)	
9	Ix-ENB	D.C. braking enabling	
10	Ix-DCB	D.C. braking control	
11	Ix-FLY	Enables the motor pickup function in free rotation (flying restart)	
12	Ix-INC	Enables the function: ramp execution	
13	Ix-DEC	Enables the function: decelerates in ramp up to zero Hz	
14	Ix-PID	PID regulator enabling	
15	Ix-P12	Selector of PID regulator coefficients	
16	Ix-INC	Increase motopotentiometer with memory (A00=5)	
17	Ix-DEC	decrease motopotentiometer with memory	
18	Ix-EF	the external fault send an ESV alarm state	

The Associated parameters, corresponding to single controls, are acting through the following actions:

PARAMETER	FUNCTION	RANGE [DEFAULT]	DESCRIPTION
Ab.03	Sets stop condition	0 1 [0]	The control causes a ramp deceleration up to zero Hz The control cuts off the voltage to the motor so that it coasts-to-stop
Ab.05	Enables motor reversal	0 1 [1]	Disables the control for motor rotation reversal Enables the control for motor rotation reversal
Ab.02	Safety	0 1 [0]	The safety command for run control is disabled Enables the safety command for run control (*)
Ab.11	Set the state of external alarm IN	0 1 [0]	Set the input as normally open (N.O.).The contact closure generates the alarm state Set the input as normally closed (N.C.).The opening generates the alarm state
Ab.06	Set external alarm action	0 1 [0]	The alarm state caused by EXTFLT locks the ESV (released only through a reset) The alarm state caused by EXTFLT disables the motor as long as the control is active
Ab.07	External alarm detection mode	0 1 [0]	Allows the ESV to detect the external alarm at any moment Allows the ESV to detect the external alarm only if the motor is running
Ab.13	Extern. alarm reset management	0 1 [0]	If EXTFLT causes the ESV lock, a manual reset only can be executed If EXTFLT causes the ESV lock, an automatic reset can be executed if Ab.14=1
Ab.36	Input filtering	0 1 [0]	A control is accepted if it acts longer than 10 ms. A control is accepted if its action lasts for 5 ms. (disturbance sensitivity increases too)
Ab.37	Term. board control management	0 1 [1]	Ignores the controls from terminal board (except EXTFLT, Ix-DE, Ix-DD) Enables the control from terminal board

9.14 Auxiliary analog input (AUX-V) - Analog output (OUT-AN)

A.41 VALUE	ACTION PERFORMED	<p>Note:The action generated by the analog voltage, variable from 0 and 10 V, depends on the value assigned to parameter A.41.</p>
0	No action	
1	Frequency reference (active if Ix-F1 =on, Ix-F2 =off, Ix-F3 =off); the frequency changes in a linear way from 0 Hz to A.01 .	
2	Adjusts the output voltage reduction by a proportional value ranging between 20% and A.65 .	
3	Adjusts the braking direct current, whose level proportionally changes between 0 and A.24 .	
4	Sets the torque threshold; the threshold value proportionally changes between 20 and A.49 .	
5	Extension factor of acceleration/deceleration ramps; proportionally changes between 1 and 10.	
6	Extension factor of acceleration ramps only; proportionally changes between 1 and 10.	
7	Changes the frequency reference in a positive way only: to the reference is added a frequency that proportionally changes between 0 and A.46 .	
8	Changes the frequency reference: to the reference is added a frequency that proportionally changes between - A.46 and +A.46 .	
9	Adjusts the boost level; the level proportionally changes between 0 and A.08 .	
10	Adjusts the boost level; the level proportionally changes between 0 and A.08 .	

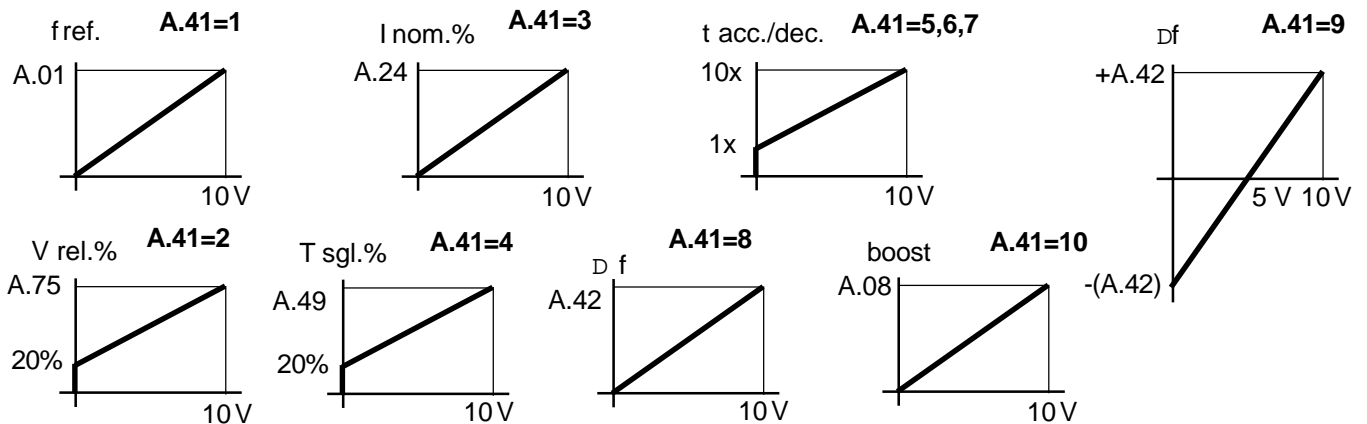

A.42 VALUE	TYPE AND MEANING OF ANALOG OUTPUT	NOTE
0	Voltage proportional to the output frequency; full scale value set by A.01 .	<p>The output voltage at terminal N.° 21 of the control terminal board, OUT-AN, can vary between 0 and 10V. The meaning assumed by this voltage depends on the value assigned to parameter A.42.</p> <p>The value of the voltage can be changed by properly programming the parameters A.43, A.44, A.45.</p>
1	10V-amplitude square wave with frequency equal to the output frequency.	
2	10V-amplitude square wave with frequency twice the output frequency.	
3	Voltage proportional to the output current; the full scale value is twice the rated I.	
4	Voltage proportional to the output voltage; full scale value set by A.16 .	
5	Analog voltage proportional to the output torque (positive only); the full scale value is twice the rated T.	
6	Analog voltage proportional to the output torque (absolute value); the sign can be obtained by one of the digital outputs.	
7	Analog voltage proportional to the output power (positive only); the full scale value is twice the motor rated power.	
8	Voltage proportional to output power (absolute value); sign obtainable by one of the digital outputs; the full scale value is twice the motor rated power.	
9	Voltage proportional to the output cos φ (positive only); full scale value is 1.	
10	Voltage proportional to the output cos φ (absolute value); the sign can be obtained by one of the digital outputs.	
11	Voltage proportional to the frequency measured at the encoder input; the full scale value is set by the value of A.01 .	
PARA METER	FUNCTION	VALUE [DEFAULT]
A.43	Adds a variable offset to the signal chosen by A.42	- 9,99 / +9,99 [0,00] (V)
A.44	Set a gain for the analog output	- 9,99 / +9,99 [1,00]
A.45	Change the time constant of the output voltage filter	0,00 / 2,50 [0,00] (s)

1: offset (**A.43**) = 3; gain (**A.44**) = 1
 2: offset (**A.43**) = 0; gain (**A.44**) = 1
 3: offset (**A.43**) = -5; gain (**A.44**) = 1
 4: offset (**A.43**) = 10; gain (**A.44**) = -1
 5: offset (**A.43**) = 10; gain (**A.44**) = -2

$V_{out} = 10 [(-\frac{S_{int}}{S_{isc}} (A.44) + (A.43)]$

9.15 Programmable digital outputs

A.39 A.40 VALUE	NAME	DIGITAL OUTPUT DISPLAYED EVENT (OUTPUT IS ACTIVE)	NOTE	
0	Ox-OK	ESV in ready state	The terminal board contains two output type : a) open-collector (OUT1 , OUT2) ; b) relay (OUT3) ; the outputs can be configured through parameters as follows: A.39 configures OUT1 A.40 configures OUT2 The outputs are active when the event shown on the table occurs. (*) Means that during startup outputs are inactive: the outputs will be active not before that the PID regulator error come into the tolerance limits at least once. The " x " in the " Name " column indicates the selected output number.	
1	Ox-AL	ESV in alarm state		
2	Ox-RUN	Motor is running		
3	Ox-STP	Motor is not running		
4	Ox-REV	Counter-clockwise rotation (in the opposite case, the output is not active)		
5	Ox-STD	ESV in steady state (end of ramp)		
6	Ox-RMP	Ramp in progress		
7	Ox-EQF	The output frequency = to programmed frequency A.47 , with hysteresis A.48		
8	Ox-NEF	" " " ≠ " " " " A.47 , " " " " A.48		
9	Ox-GTF	" " " >than " " " " A.47 , " " " " A.48		
10	Ox-LTF	" " " < than " " " " A.47 , " " " " A.48		
11	Ox-RN1	Ramp end (disabled when the output freq. is < than programmed freq. A.47)		
12	Ox-RN2	Output frequency < than programmed frequency A.47 (disabled at ramp end)		
13	Ox-UV	Undervoltage with running motor (not depends from short mains blackout)		
14	Ox-GTT	Output torque > than the torque set by A.49 (and AUX-V , if enabled)		
15	Ox-IL			current
16	Ox-VL	In case of ramps extension for limitation of :		voltage
17	Ox-IVL			current or voltage
18	Ox-FLY	When the motor pickup occurs		
19	Ox-BRK	The dynamic braking circuit is faulty		
20	Ox-CFI	The cos φ sign is negative		
21	Ox-ERP	The PID regulator error is :		>(A.82) and < -(A.83)
22	Ox-EPP			> (A.82)
23	Ox-EPN			< -(A.83)
24	Ox-ERP(*)	The PID regulator error is :		>(A.82) and < -(A.83)
25	Ox-EPP(*)			> (A.82)
26	Ox-EPN(*)		< -(A.83)	

9.16 Dynamic braking - Direct current braking.

PARAMETER	FUNCTION	VALUE [DEFAULT]	DESCRIPTION
Ab.22	Thermic protection of the braking resistor	0 = off 1 = on [0]	<p>Ab.22=1 enable the thermic protection of the braking resistor. The protection efficiency depends on the accuracy of parameters A.53, A.54, A.55. The protection level reached can be displayed through parameter d-11, expressed in %.</p> <p>When the level reaches 100%, the protection locks the inverter.</p> <p>During the braking phase, in case of shortcircuit of the inner braking device, the corresponding signalling can be displayed through terminal board by properly configuring the Ox-BRK output. The only action to be performed in case of shortcircuit is to cut the inverter supply off.</p> <p>NOTE: The wiring terminals of the braking resistor are NOT short circuit PROTECTED or protected by improper value (lower than minimum expected) of the resistors used : in these cases the inverter will be permanently damaged.</p> 
A.53	Ohmic value of the braking resistor (Ω)	1 - 250 [(**)]	
A.54	Resistance power of the braking resistor (W)	10 - 2500 [(**)]	
A.55	Thermic constant of the braking resistor (s)	5 - 1250 [(**)]	

[(**)] = The default values of the parameters depends on the inverter size.

PARAMETER	FUNCTION	VALUE [DEFAULT]	DESCRIPTION
A.24	D. C. braking level (% of P-02)	0 - 100 [0]	<p>Defines the D.C. value expressed in % of A.16 from which the value of the braking current depends.</p> <p>The aim of D.C. braking is to keep the motor locked in a fixed position, it is not an alternative to the ramp deceleration. The D.C. braking consist in forcing a direct current that depends from the voltage set by A.24 and the electrical characteristics of the motor into a motor phase (ph. U). With D.C. braking, the deceleration time is shorter than in case of coast to stop. Sometime, at startup, it may be useful to lock the motor for a preset time before starting the acceleration ramp.</p> <p>The braking current intensity can also be adjusted through the terminal board by means of a 0/10V signal applied to the AUX-V input (configured with A.41=3): the current value changes proportionally to the 0/10V signal between 0 and the value fixed through parameter A.24.</p> <p>The function can also be enabled or disabled through terminal board by configuring one of the programmable inputs (Ix-ENB) as a control.</p> <p>It is always possible to force a direct current on the motor, independently of the values assumed by the parameters, by configuring one of the terminal board programmable inputs (Ix-DCB) as control of for D.C. braking.</p> <p>During the D.C. braking, at parameter d-00 the display shows the message " dcb " instead of the frequency.</p>
A.25	Limit frequency below which the braking is forced (Hz)	0,0 / 480,0 [0,0]	
A.26	Set the braking duration at startup (s)	0,0 / 60,0 [0,0]	
A.27	Set the braking duration in stop phase (s)	0,0 / 60,0 [0,0]	

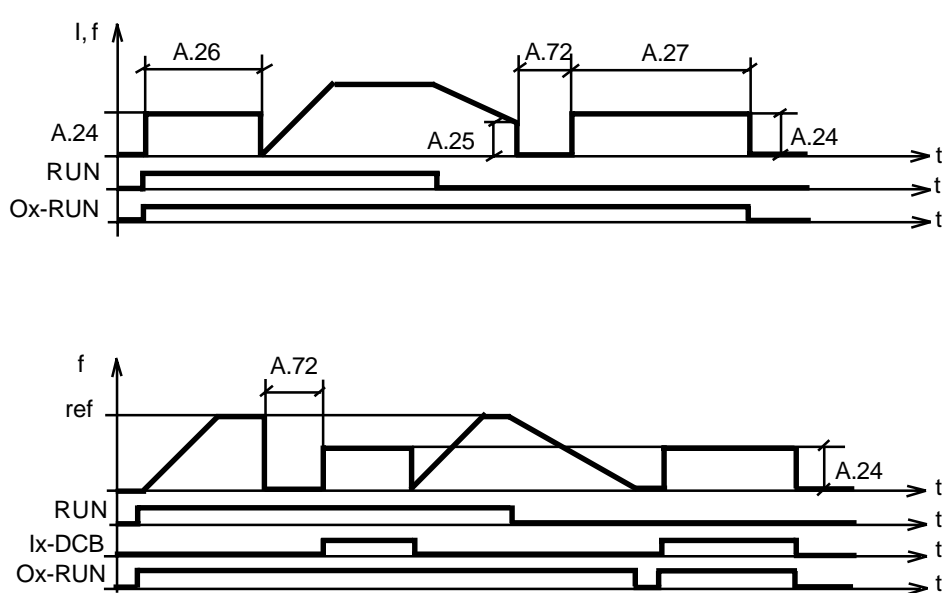

The diagram illustrates the relationship between current (I) and frequency (f) during D.C. braking. The top graph shows current I and frequency f over time t. It includes parameters A.24 (braking level), A.25 (limit frequency), A.26 (braking duration at startup), A.27 (braking duration in stop phase), and A.72 (braking duration). The bottom graph shows frequency f over time t with parameters A.72 and A.24. Both graphs show RUN, Ix-DCB, and Ox-RUN signals.

9.17 PID regulator				
PARAMETER	FUNCTION	VALUE [DEFAULT]		ACTION PERFORMED
Ab.38	PID regulator enabling	0 = off	1 = on [0]	The regulator is active with running motor only.
Ab.39	Disables the regulator action in ramp phase	0 = off	1 = on [0]	1 interrupts the regulator action during the ramp phase.
Ab.40	Allows regulator updating period to be locked to the encoder	0 = off	1 = on [0]	
Ab.41	Select the controlled parameter	0 = frequency	1 = voltage [0]	0 : controls the output frequency; full scale is defined by A.01 1 : controls the output voltage; full scale value defined by A.16 ;
Ab.42	Reverts the error signal sign	0 = off	1 = on [0]	The sign of the error signal between reference and feedback is reversed (and the adjustment effect too).
Ab.43	Modality of control	0 = direct	1 = (feed forward) [0]	1 : the reg. output is added to the freq. reference value or to the voltage value provided by the V/F characteristic; 0 : the output act as set by Ab.41 .
Ab.44	Suppress the regulator positive output	0 = off	1 = on [0]	Limits the regulator output in the positive direction; 0 allows the output to assume positive values too.
Ab.45	Suppress the regulator negative output	0 = off	1 = on [0]	Limits the regulator output in the negative direction; 0 allows the output to assume negative values too.
Ab.46	Suppress the integral term	0 = off	1 = on [0]	Allows for integral term to match the limits set to the output by Ab-46 and A b-47 .
Ab.47	Initialisation of the integral term at startup	0 = off	1 = on [0]	Allows the initialization by means of the run control. NOTE : this could cause a very slow response of the regulator, even with high gains.
A. 81	PID regulator reference (%)	0,0 - 100,0 [0,0]		The reference value is derived through the setting of the selector parameters shown on the following table.
A. 82	PID maximum positive error (%)	0,1 - 100,0 [5,0]		Defines the max. positive excursion of the regulator error expressed in % of the full scale value.
A. 83	PID maximum negative error (%)	0,1 - 100,0 [5,0]		Defines the max. negative excursion of the regulator error expressed in % of the full scale value
A. 84	PID regulator update time (s)	0,00(=0,005s) - 2,50 [0,00]		Defines the regulator update time.
A. 85	Proportional term gain - Kp1	0,00 - 99,99 [0,00]		The regulator enabling and the coefficients selection can be made through terminal control board by configuring two out of the five control inputs as Ix-PID and Ix-P12 input respectively: Ix-PID = 1 the PID regulator is controlled from the terminal board. Ix-P12 = 1 selects the coefficient set N. 1; 0 refers to set 2. When enabling the regulator or changing the coefficients set, the integral term is used according to the present output and coefficients, by taking into account possible limits applied to the output and to the integral term; this avoid sudden output changes ("bumpless" operation). If the coefficient change occurs when the error is significant, the system response speed is affected by the integral action weight, as the proportional and derivative term weight is compensated by the integral term. A max. tolerance interval can be defined for the error that, if exceeded, actuates a signalling available on the terminal board by properly configuring one of the digital outputs: OUT1 , OUT2 . The error tolerance control is enabled when the error falls within the preset interval for the first time (A.44 value: 21, or 22, or 23). During startup transient (that is: not before the regulator error falls within the tolerance limits at least once), it is possible to disable the outputs through A.39 value 24, or 25, or 26. The possible sign reversal made by setting Ab42=1 has no importance for tolerance control. The out-of-tolerance signaling available on the digital outputs can be enabled when exceeding one of the two limits (Ox-ERP), or the positive (Ox-EPP) or negative (Ox-EPN) limit only. To facilitate the parameters setting, the following items can be displayed: reference signal: code d-22 on display, feedback signal: code d-23 , " error: code d-24 , " integral component: code d-25 , " output: code d-26 , " NOTE: The integral term is set to zero if the integral action time is set to the max. value, i.e. 99.99. The derivative term is null if the derivative action time is set to zero.
A. 86	Integral action time - Ti1	0,00 - 99,99 [99,99]		
A. 87	Derivative action time - Td1	0,00 - 99,99 [0,00]		
A. 88	Proportional term gain - Kp2	0,00 - 99,99 [0,00]		
A. 89	Integral action time - Ti2	0,00 - 99,99 [99,99]		
A. 90	Derivative action time - Td2	0,00 - 99,99 [0,00]		
		feedback switches		
		Ab.53	Ab52	Ab.51
fixed at 0		0	0	0
freq. from encoder input		0	0	1
AUX-V		0	1	0
REF-V		0	1	1
REF-I		1	0	0
Iout(10V=2*I _{nom})		1	0	1
Tout(10V=2*T _{nom})		1	1	0
Pout(10V=2*P _{nom})		1	1	1
		reference switches		
		Ab50	Ab49	Ab48
reference frequency		0	0	0
freq. from encoder input		0	0	1
AUX-V		0	1	0
REF-V		0	1	1
REF-I		1	0	0
P-90 in % of full scale		1	0	1
freq. downstream ramp gener.		1	1	0
fixed at 0		1	1	1

9.18 Reset - Autoreset - Protections and alarms

FUNCTION	DESCRIPTION			
Reset	Operation to be executed when the ESV is in alarm state. Three possibilities are available: a) Keyboard reset: simultaneously press the ϵ and ι keys : the action will have effect when the keys are released. b) Terminal board reset: it can only be performed if one of the programmable control inputs has been configured as Ix-RES . In this case, the reset operation is enabled when switching from active to inactive control. c) Cut the ESV supply off, wait until it is completely off, supply the ESV again.			
Autoreset	As an alternative to manual reset, this function allows an automatic restart in case of lock due to protection tripping. It can only be enabled if the lock is due to: overcurrent, overvoltage, undervoltage, momentary overload, external alarm (b-11) and is controlled by the parameters defined on the following table:			
PARAMETER	FUNCTION	VALUE [DEFAULT]	DESCRIPTION	
Ab.14	Autoreset enabling	0 = off 1 = on [0]	In case of lock, it automatically restarts the ESV.	
Ab15	Enable autoreset attempts limitation	0 = off 1 = on [0]	Allows for limiting the number of attempts made by the ESV to execute the autoreset.	
Ab.16	Enable the automatic set at zero the number of attempts	0 = off 1 = on (10 min.) [0]	Sets to zero the number of attempts performed, if no further locks occur within 10 min.	
Ab.17	Set the state of the alarm contact during the autoreset.	0 = disabled 1 = enabled [1]	During autoreset, it disables the lock signalling contacts on the terminal board if allowed, through parameter setting, to perform the alarm function.	
A.51	Delay to start the autoreset function (s)	0,1 - 60,0 [5]	Defines the time, as regards the lock enabling moment, after which the autoreset (restart) is executed.	
A.52	Set the max. number of restart attempts	1 - 250 [1]	Sets the max. number of restart attempts after which the ESV remains in lock state. To restart, execute a manual reset.	
CODE ON DISPLAY	FUNCTION	DESCRIPTION		CODE
C.Err	Full lock (alarm contact enabled)	Configuration memory error. It is enabled at ESV startup if the configuration memory is not working properly. To avoid this, try to turn the ESV off and restart it after some minutes.		
P.Err		Parameter memory error. It is enabled if the memory contains inconsistent parameters. Causes: accidental loss of parameters (turning off during storage phase), memory failure. In case of accidental loss: turn the ESV off and restart it after some minutes. The factory-preset parameters will be stored.		
EF	Lock that can be reset (alarm contact enabling and storage of alarm type, the display is flashing)	External protection: enabled by the EXTFLT input on terminal board. Autoreset can be enabled only if parameter Ab.13=1 .		1
OC		Overcurrent protection: enabled when the output current exceeds, even momentary, the max. allowed threshold to protect the ESV. It signals shortcircuits between phases and to ground too.		2
Ov		Overvoltage protection: enabled when the voltage at the filter capacitor ends exceeds the max. programmed threshold to protect the ESV.		3
Uv		Undervoltage protection: enabled when the voltage at the filter capacitor ends falls below the min. threshold programmed to avoid troubles due to torque reduction. Autoreset is allowed. If Ab.35=0 , the alarm storage is disabled.		4
OH		Overtemperature protection: enabled when the heat sink temperature exceeds the max. threshold programmed to protect the inverter. Autoreset is not allowed.		5
OLi		Inverter overload protection: enabled when the direct current exceeds the max. threshold for the max. allowed time (I_xT) to protect the inverter. Autoreset is not allowed.		6
OLm		Motor overload protection: enabled when the direct current exceeds the max. threshold for the max. allowed time (I₂xT), to protect the motor. The levels and times depend on setting of the motor characteristic data. Autoreset is not allowed.		7
OLr		Braking resistor overload protection: enabled when the power dissipated by the braking resistor exceeds the max. threshold for the max. allowed time. The levels and times depend on setting of the resistor characteristic. Autoreset is not allowed.		8
OT		Protection for momentary motor overload: it is active, after enabling (Ab.19=1), when the torque delivered by the motor exceeds the programmed level for the preset time, to protect the connected mechanical parts or the worked material.		9
PH		Protection for supply phase lack (valid for 3-phase supply only): enabled 30 s. after one of the supply phases has been disconnected. Autoreset is not allowed.		10
FU	Fuse breakage protection: enabled in case of inner fuse breakage. Autoreset is not allowed.		11	

Serial line

DESCRIPTION

The ESV can communicate with a remote controller through a RS-485 2-wire serial line. In this case, the ESV behaves like a "slave", i.e. it answers on special controller request only (master). Up to 32 ESV can be parallel connected with addresses set between 1 and 99 through **A.59**.

The address **99** is a specialized one since it is expected that it will be used when it is necessary to send a code to all ESV simultaneously; in this case the reception of the code is assured to all ESV regardless of the individual address, the acknowledgement will be made only from the ESV with address 99.

The serial line allows reading and writing all the parameters, forcing the various controls by replacing the keyboard or the terminal board, or forcing the I/O as in a PLC. The parameters involved are:

PARAMETER	FUNCTION	VALUE [DEFAULT]	DESCRIPTION
A.56	Enables the control of inputs from serial line	0 - 255 [0]	The parameter value is a decimal equivalent of the current value of the 8 bit input register SX8 (see the serial communication handbook)
A.57	Enables the control of outputs from serial line	0 - 15 [0]	The parameter value is a decimal equivalent of the current value of the 8 bit output register SX8 (see the serial communication handbook)
A.58	Defines the transmission parameters	0 - 19 [1]	See the following table
A.59	Assign an address to each ESV	0 - 99 [0]	Assign the unique address between 0 - 99 to each ESV
A.60	Set the response delay time of the ESV	0 - 250 [1] (ms)	The delay time between the receipt of the command and the emission of the answer
Ab.37	Enables the terminal board control	0 = off 1 = on [0]	The scope of the parameter is to disable the control of the ESV from the terminal board to avoid conflicts with the serial line.

A.58 VALUE	BAUD RATE	DATA BIT	PARITY	STOP BIT	A.58 VALUE	BAUD RATE	DATA BIT	PARITY	STOP BIT
0	9600	7	even	1	10	2400	7	no	2
1	9600	7	odd	1	11	2400	8	no	1
2	9600	7	no	2	12	1200	7	even	1
3	9600	8	no	1	13	1200	7	odd	1
4	4800	7	even	1	14	1200	7	no	2
5	4800	7	odd	1	15	1200	8	no	1
6	4800	7	no	2	16	19200	7	even	1
7	4800	8	no	1	17	19200	7	odd	1
8	2400	7	even	1	18	19200	7	no	2
9	2400	7	odd	1	19	19200	8	no	1

9.19 AUXILIARY KEYBOARD [code AUX TST]

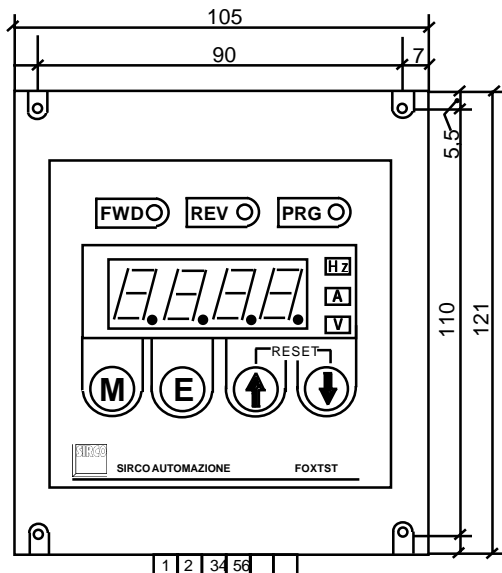

The auxiliary keyboard take the place of the on board keyboard when, for mounting reasons, it is not possible to reach the control panel. It performs the same functions as the control panel.

As in the control panel, there are:

- 4 keys: **Enter**, **Menù**, **UP**, **DOWN** (simultaneously press **UP** and **DOWN** to reset the alarm)
- 4 7-segment digit to displays all parameters.
- 3 Led indicating: forward run, backward run, storage status.
- further 3 Led to indicate the units of parameter value displayed.

The auxiliary keyboard is equipped with a 6-wire extension cable, 2 m. long. This cable must be connected : one side to the connector on the control board to the left of control circuit terminals, the other side to the connector on the front, lower side, of the auxiliary keyboard. Anything else is required to operate the auxiliary keyboard.

PROGRAMMING KEY [code K-PRGE]



The programming key device allows for transferring parameters from and to the ESV or between ESV.

The data are stored in a E²PROM type memory, so battery backup is not necessary. The switch put on upper front of the key allows to write protect the stored data.

To copy data from an ESV to the key or viceversa the keypad panel are used.

PROGRAMMING KEY: use method

- Parameter transmission from the key to the ESV:

- plug the key in the appropriate connector on internal board
- select the parameter **C - 04**, go to the code **7** press **E**.

If the key contains invalid parameters, the factory-preset parameters will be used and the message " Err" will be displayed for 4 sec. Otherwise, data will be permanently stored and the confirmation message " done" will be displayed for 2 sec.

- Parameter transmission from the ESV to the key:

- plug the key in the appropriate connector on internal board
- select the parameter **C - 05**, go to the code **7** press **E**.

If the key is write-protected, the control is interrupted and the message " off" is displayed for 4 sec. Otherwise, the ESV parameters are stored on the key and, at the end of the operation, the message " done" will be displayed for 2 sec. to confirm the operation.

REMOTATION CABLES OF SIGNAL COMMAND

Cable with connector type IO1 of principal signal. Lengths: 1,3,5,10m

Cable with connector type IO1+IO2 .Lengths: 1,3,5,10m

Cable with connector type LINK for serial link RS485 by remote terminal or microcomputer systems , PLC etc. lengths: 1,3,5,10m

Cable with connector type DISPLAY to remote AUX TST. Lunghezze 1,3,5m

Connector AMP type 280362/0 used for IO1

Connector AMP type 280360/0 used for IO2 and DISPLAY

Connector AMP type 280359/0 used for LINK

Contact AMP type 280708/0 to assemble previous connectors

Potenzimetro 5 Kohm linear